

ROD STYLE ROLLER SCREW ACTUATOR COMPARISON

ERD HYGIENIC ROD-STYLE ACTUATOR

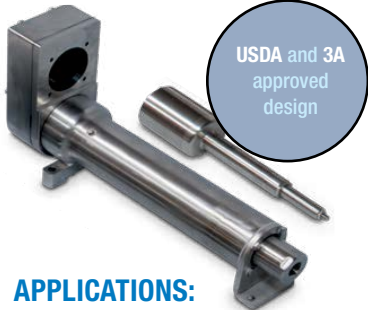

USDA and 3A approved design

APPLICATIONS:

- Low to medium thrust forces for externally guided and supported loads
- Pneumatic and hydraulic cylinder replacement

FEATURES:

- Stainless steel main tube & thrust tube
- Compatible with many commercially available metric rod end accessories
- Ball, roller or solid nut assemblies
- NEMA or metric motor mount
- Rugged nose and main bearings
- Patented

OPTIONS:

- Trunnion, foot or front flange mounts
- IP67 & IP69K ingress protection, stainless steel with protective motor enclosure
- Load guidance, tooling plate and anti-rotate
- Reed, solid state PNP or NPN switches

SPECIFICATIONS:

	ERD	10	15	20	22	25	30
MAX. STROKE	in	10	24	24	39.4	39.4	39.4
	mm	254	609	609	1000	1000	1000
MAX. THRUST	lbf	100	200	500	1700	3300	7868
	N	445	890	2224	7562	14679	34999
MAX. SPEED	in	40	40	20	50	58	58
	per sec	mm	1016	1016	508	1270	1473

RSA ROD-STYLE ACTUATOR



Speeds to 6 m/sec
Forces to 58 kN
(13039 lbf)

APPLICATIONS:

- Medium to high thrust forces for externally guided and supported loads
- Pneumatic and hydraulic cylinder replacement

FEATURES:

- Non-rotating, salt bath nitride treated thrust tube
- Internally threaded rod end
- Anodized aluminum design

OPTIONS:

- HT option for high thrust applications
- IP67 option for ingress protection
- Ball, roller or solid nut assemblies
- Trunnion, clevis, eye, flange or foot mounts
- Clevis, eye, threaded rod or coupler rod mounts
- Inline or reverse-parallel motor mount
- Reed or solid state position sensors

SPECIFICATIONS:

	RSA or RSM	12	16	24	32	50	64
MAX. STROKE	in	12	18	24	36	48	60
	mm	305	457	610	914	1219	1524
MAX. THRUST	lbf	130	130	1700	4159	7868	13039
	N	578	578	7562	18500	34999	58001
MAX. SPEED	in	123	123	50	50	50	58
	per sec	mm	3124	3124	1270	1270	1270

IMA INTEGRATED MOTOR/ACTUATOR



Ask about native AB Kinetix® drives compatibility

APPLICATIONS:

- High thrust forces for externally guided and supported loads
- Pneumatic and hydraulic cylinder style operation in a compact design

FEATURES:

- Integral hollow rotor servo motor
- Integral high resolution feedback device
- Salt bath nitride treated thrust tube
- Grease port (patented) for internal lubrication without disassembly

OPTIONS:

- Roller or ball nut assemblies
- Trunnion, clevis, eye, front flange or plate mounts
- Clevis, eye, or external thread rod mounts
- Integral holding brake
- Choose from popular motor manufacturers' connectors and feedback devices

SPECIFICATIONS:

	IMA	22	33	44	55
MAX. STROKE	in	12	18	18	18
	mm	305	457	457	457
MAX. THRUST	lbf	325	1000	1700	2000
	N	1446	4448	7562	8896
MAX. SPEED	in	28	48	24	52.5
	per sec	mm	711	1219	610

RSX ROD-STYLE ACTUATOR*



Forces to 133.5 kN
(30,000 lbf)

APPLICATIONS:

- High thrust forces for externally guided and supported loads
- Hydraulic cylinder replacement

FEATURES:

- Non-rotating, salt bath nitride treated thrust tube
- Externally threaded rod end
- Roller screw drive
- Steel tie rod/hard coat anodized aluminum design

OPTIONS:

- IP69K option for ingress protection
- Trunnion, front flange, rear clevis or mounting plates
- Rod clevis or threaded rod mounts
- Inline or reverse-parallel motor mount

SPECIFICATIONS:

	RSX	**080	096
MAX. STROKE	in	59	59
	mm	1500	1500
MAX. THRUST	lbf	18000	30000
	N	80068	133450
MAX. SPEED	in	27.6	29.9
	per sec	mm	700

*RSX is a 20 day built-to-order product.
**Coming soon

WIDE RANGE OF CAPABILITIES • CONFIGURABLE STROKES • CLEAN LEAK-FREE PERFORMANCE • FAST DELIVERY

Planetary (standard) roller screw linear actuators

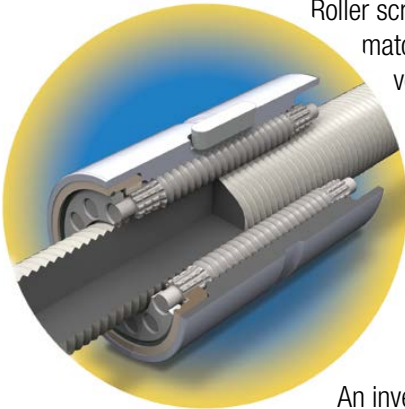

Roller screws (also called planetary roller screws) have triangular-shaped, precision-ground threads that match multiple precision-ground threaded rollers in the nut. These rolling elements transmit force very effectively. Roller screw components are designed with a fine pitch, providing more points of contact and a larger contact radius. The result is less stress per point of contact.

Roller screws have very high force transmission capabilities since the rollers have significant contact with the screw threads. They can deliver high force, operate at high speeds, are long-lasting and require little maintenance. The use of planetary roller screws is allowing engineers to specify electric actuators in applications that were once the sole province of hydraulic cylinders.

An inverted roller screw operates much the same as a standard roller screw except the functions of the nut and screw are reversed. The rollers move inside the nut.

Most inverted roller screws used in linear actuators are produced using a process other than grinding to inexpensively create threads inside the nut. The hardening process is performed after the nut is machined and results in a much shallower case hardness depth and softer threads than those of standard roller screws. This leads to a significantly lower DLR* (lower life) and more challenges with maintaining lubrication.

Tolomatic manufactures standard roller screws for use in their electric actuators. These screws are case (surface) hardened before precision grinding, resulting in very deep case hardness and high Dynamic Load Rating (DLR*).

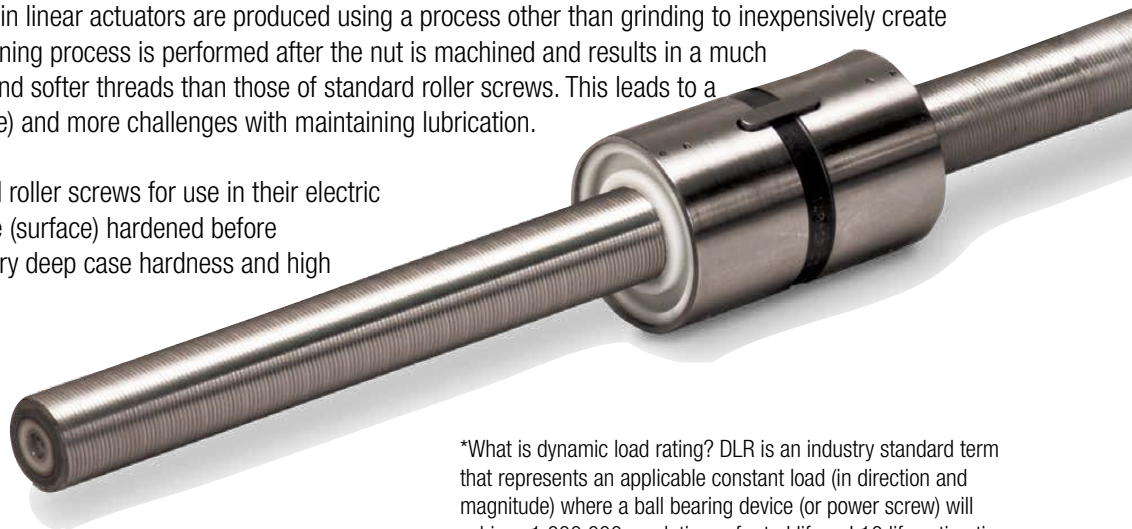

*What is dynamic load rating? DLR is an industry standard term that represents an applicable constant load (in direction and magnitude) where a ball bearing device (or power screw) will achieve 1,000,000 revolutions of rated life or L10 life estimation at 90% reliability. DLR is usually provided by the manufacturer.