

### MXB63U Unguided, Belt-Drive Actuators

63mm (2-1/2 inch) Series

Models: MXB63UBWS50

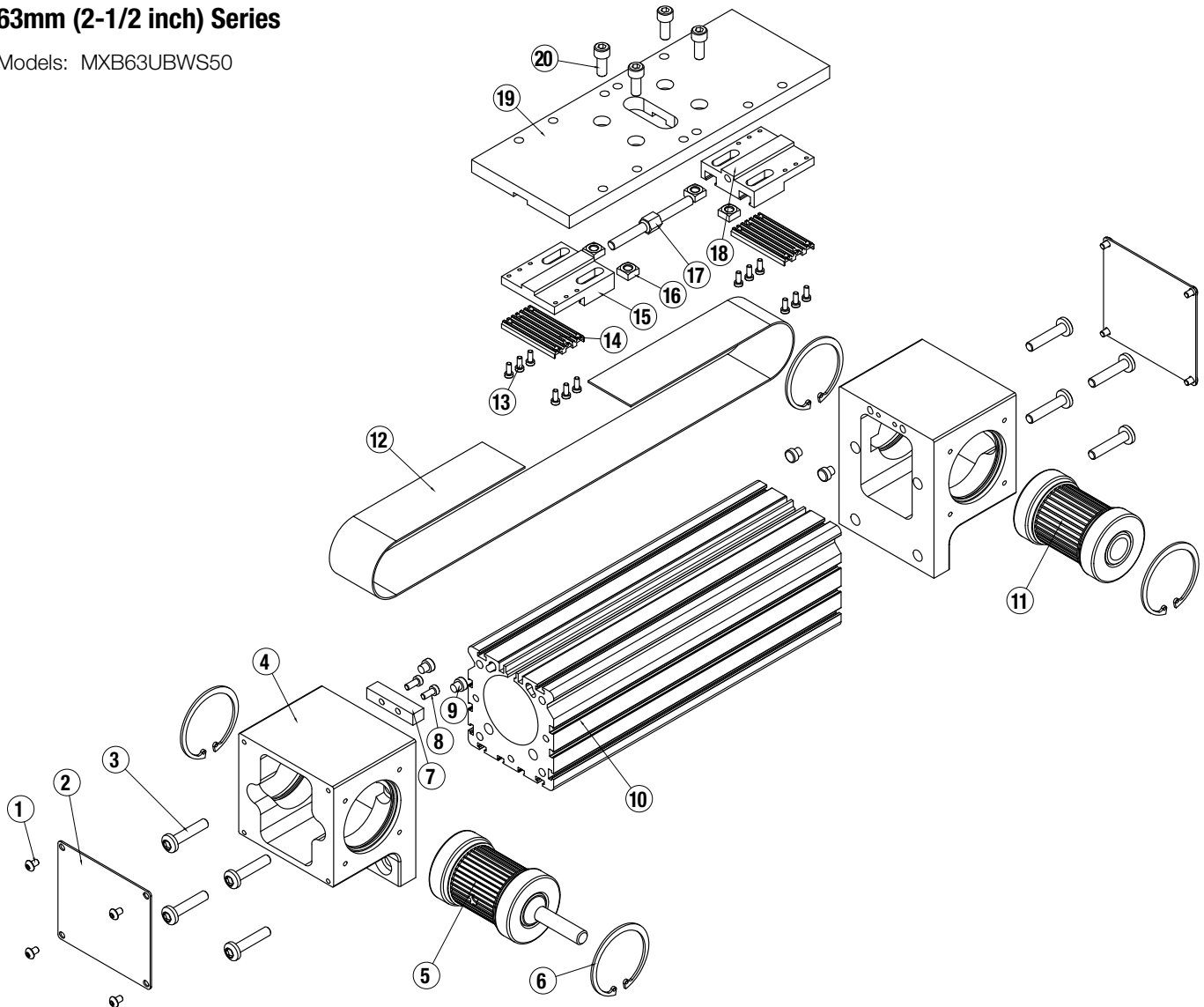

ITEM	PART NO OR CONFIG. CODE	DESCRIPTION	QTY.
1.	8540-1026	BUTTON HEAD CAP SCREW	8
2.	8563-1020	END COVER PLATE	2
3.	8350-1023	HEAD SCREWS	8
4.	8563-1000	HEAD	2
5.	8563-9026	DRIVE PULLEY ASSEMBLY	1
	8563-9027	DRIVE PULLEY ASSEMBLY, DUAL	1
6.	8563-1025	RETAINING RING	4
7.	8563-1032	SPACER	1
8.	3420-1644	SOCKET HEAD CAP SCREW	2
9.	8525-1002	BUMPER	4
10.	RTBMXB63_SK_	TUBE (US CONV)	A/R
	RTBMXB63_SM_	TUBE (METRIC)	A/R
11.	8563-9028	IDLE PULLEY ASSEMBLY	1

ITEM	PART NO OR CONFIG. CODE	DESCRIPTION	QTY.
12.	RBMXB63_SK_	BELT (US CONV)	A/R
	RBMXB63_SM_	BELT (METRIC)	A/R
13.	8125-1070	LOW HEAD CAP SCREWS	12
14.	8563-1005	BELT CLAMP BOTTOM	2
15.	8563-1004	BELT CLAMP, LH	1
16.	8563-1027	NUT	4
17.	8540-1006	TURNBUCKLE	1
18.	8563-1003	BELT CLAMP, RH	1
19.	8563-1041	CARRIER (METRIC)	1
	8563-1042	CARRIER, BLANK	1
	8563-1541	CARRIER (US CONV)	1
20.	0604-1038	SOCKET HEAD CAP SCREW	4

A/R = As Required

<sup>1</sup> Replacement ordering method using config code: □□□ MXB63U BWS50 SK□□□□

**EXAMPLE:** RTB MXB63U BWS50 SK21.25

Tube (RTB) or Belt (RB); □ Model & Size | □ Belt Size | □ Stroke Length  
Bearing Style

Drawing Repeated For Reference

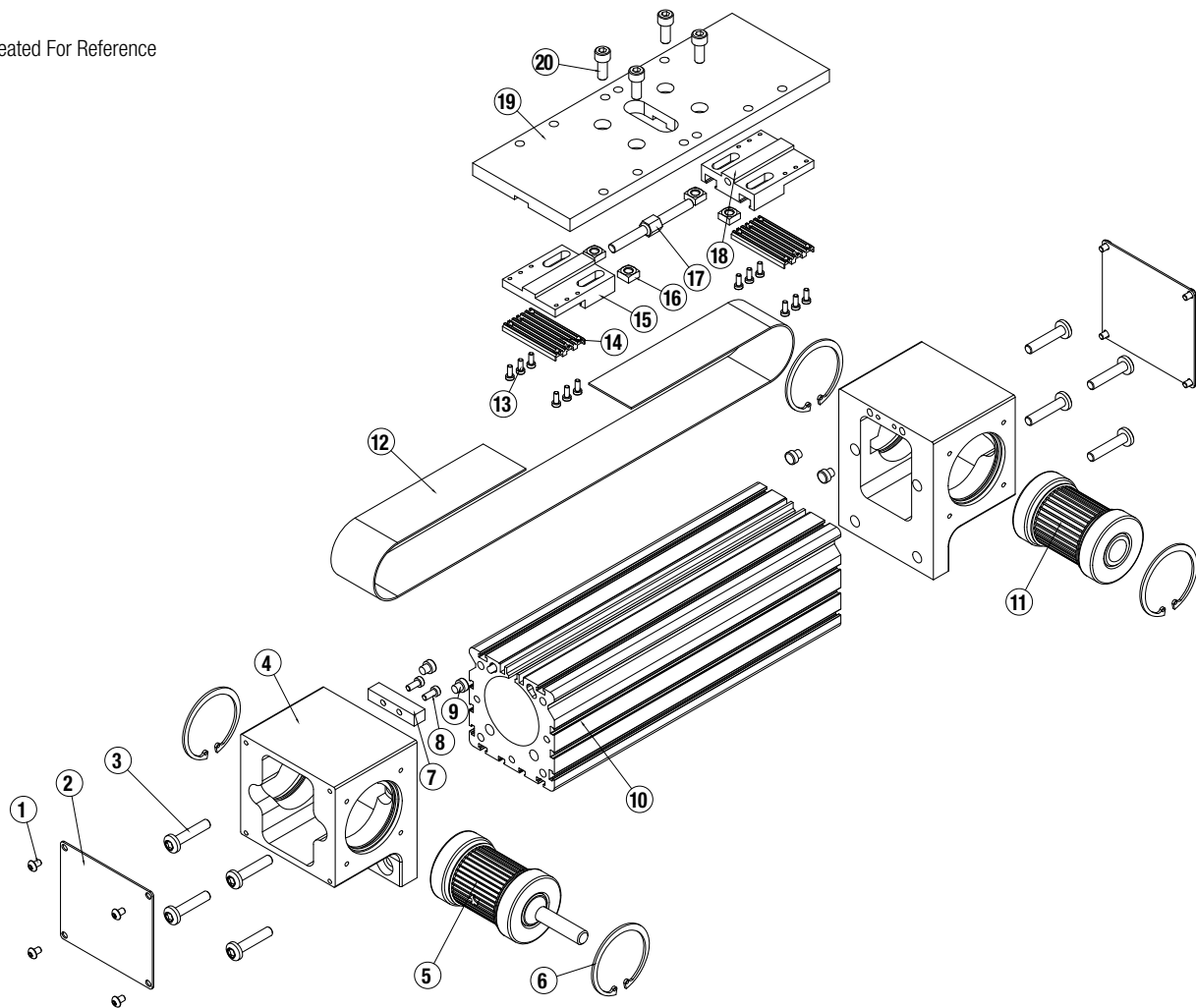

### General Actuator Disassembly

1. Remove End Cover Plates (2). Remove Low Head Cap Screws (20). Remove Carrier Plate (19) exposing the Belt Clamps (15, 18) and the Turnbuckle (17). Loosen the Turnbuckle (17) removing all belt tension.
2. Remove the Belt (12) from the Belt Clamps (15, 18) by removing Fasteners (13) and Belt Clamp Bottom (14). The Belt (12) can now be removed from the actuator.
3. Remove the Retaining Rings (6) from each of the Heads (4). Note that the Bearing/Pulley Assemblies (5, 11) are slip fit into the Head (4), but are bonded in the bore w/ Retaining Compound (Loctite 641 or equivalent), so it may be necessary to press the Pulley Assemblies (5, 11) out of the Head (4).
4. Remove the Heads (4) from the Tube (10) by removing Fasteners (3).

### General Actuator Assembly

1. Install the Drive and Idle Heads (4) to the Tube (10). Note that the Bumper Spacer (7) installs onto the Drive End Head (4).
2. Install one Retaining Ring (6) into each Head (4). Apply a light coating of Retaining Compound (Loctite 641 or equivalent) to the outside diameter of the bearings of the Pulley Assemblies (5, 11) and to the inside diameter of the bearing bores of the Head (4). Install the Drive

and Idle Pulley/Bearing Assemblies (5, 11) into the Heads (4). Note that orientation of the drive shaft is determined by this assembly step. Install the remaining Retaining Ring (6) into each Head (4).

3. Feed the Belt (12) into the Tube (10) from one end of the actuator. Install a Belt Clamp (15, 18) to each end of the Belt (12) with Belt Clamp Bottoms (14) and Fasteners (13). Note that one Belt Clamp (15) will have left hand threads for the Turnbuckle (17). Assemble so that Belt Clamp LH (15) is nearest the drive end Head (4). Start the Turnbuckle (17) into each of the Belt Clamps (15, 18). Position Hex Nuts (16) in their respective slots of the Belt Clamps (15, 18).
4. Position Carrier Plate (19) over the Belt Clamps (15, 18) and install Fasteners (20), leaving loose at this time.
5. Tension the Belt: To measure belt tension, position the edge of the Carrier Plate (19) that is nearest the Head (4) 6" from the inside edge of the Head (4) (either end of the actuator). Locate a force gage on the Belt (12) 2" from the inside edge of the Head (4). Support the tube side of the Carrier Plate (19) so that it is rigid to the Tube (10). Deflect the Belt (12) 1/4" [6 mm] in either direction. The force gage should read between 18 and 22 lbs. [80 - 98 N]
6. Adjust the Turnbuckle (17) to achieve this tension, then tighten the Fasteners (20) to secure the Belt Clamps (15, 18) to the Carrier Plate (19).

### Direct Drive Motor Mounting Option

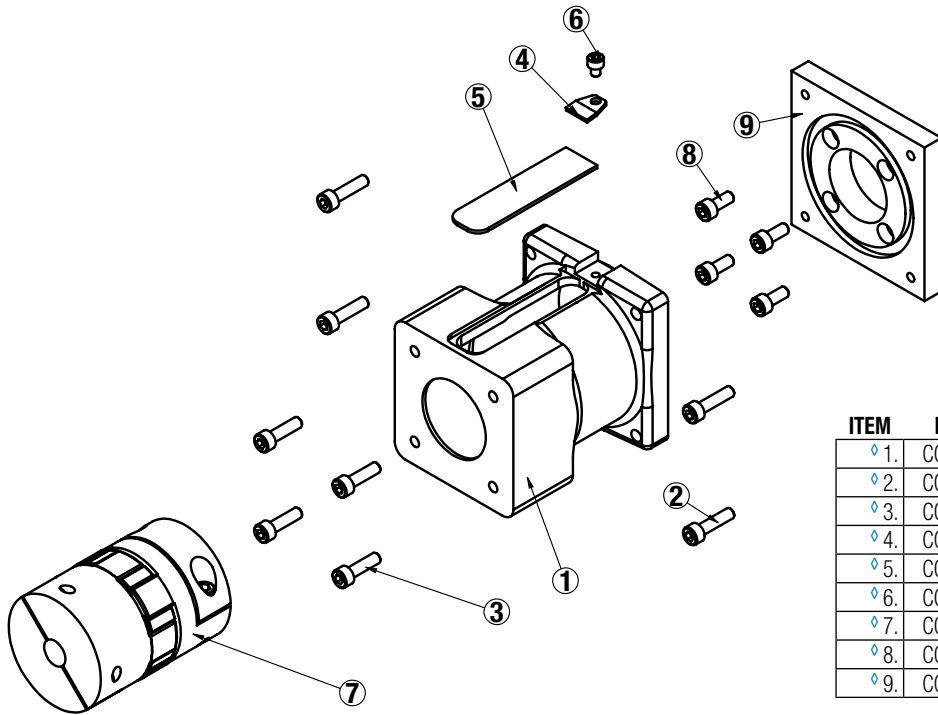

ITEM	PART NO.	DESCRIPTION	QTY
◇ 1.	CONFIGURED	MOTOR SPACER	1
◇ 2.	CONFIGURED	SOCKET HEAD CAP SCREWS	4
◇ 3.	CONFIGURED	SOCKET HEAD CAP SCREWS	4
◇ 4.	CONFIGURED	CLAMP	1
◇ 5.	CONFIGURED	COVER	1
◇ 6.	CONFIGURED	SOCKET HEAD CAP SCREWS	1
◇ 7.	CONFIGURED	COUPLER	1
◇ 8.	CONFIGURED	SOCKET HEAD CAP SCREWS	4
◇ 9.	CONFIGURED	ADAPTER PLATE	1

◇ Part number varies depending on YMH (Your Motor Here).  
Contact help@tolomatic.com for replacement part number.

A replacement Motor Mount Kit contains all parts listed above.

Replacement Motor Mount Kits ordering method: **MMK MXB63U**     **YM**

**EXAMPLE: MMK MXB63U S D L Y M O T B D O**  
 Motor Mount Kit ———— | ———— | ———— | ———— | ————  
 Model & Size            Bearing Style    Mounting Style            Motor Code

## Reverse Parallel Reduction Drive Option

3:1 Reduction Drive

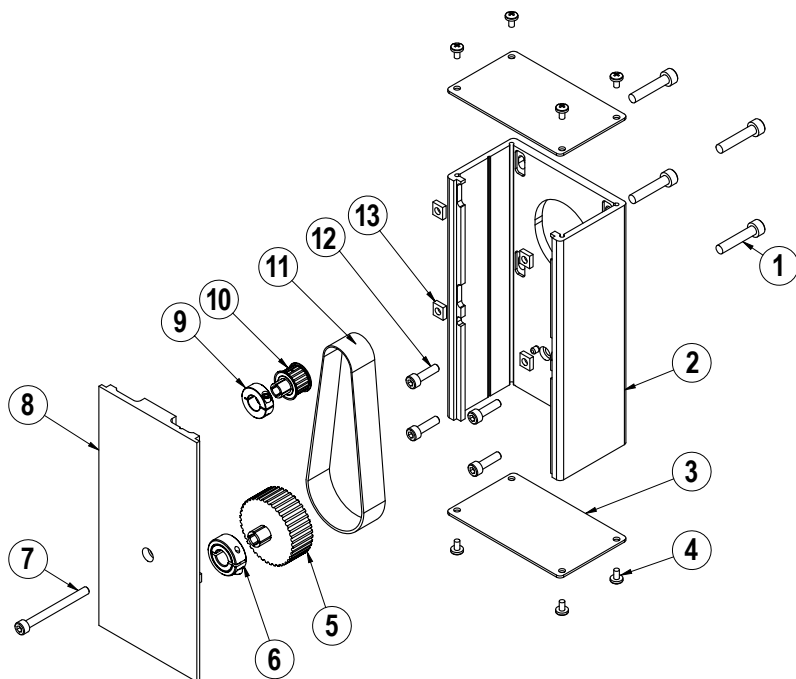

ITEM	PART NO.	DESCRIPTION	QTY.
◊1.	CONFIGURED	MOTOR FASTENER	4
◊2.	CONFIGURED	RP HOUSING	1
◊3.	CONFIGURED	RP HOUSING END CAP	2
◊4.	CONFIGURED	END CAP SCREW	8
◊5.	CONFIGURED	DRIVE SHAFT PULLEY	1
◊6.	CONFIGURED	COLLAR CLAMP, DRIVE SHAFT	1
◊7.	CONFIGURED	RP COVER FASTENER	1
◊8.	CONFIGURED	RP COVER	1
◊9.	CONFIGURED	COLLAR CLAMP, MOTOR	1
◊10.	CONFIGURED	MOTOR PULLEY	1
◊11.	CONFIGURED	BELT	1
◊12.	CONFIGURED	RP PLATE FASTENER	4
◊13.	CONFIGURED	SQUARE NUT	4

◊ Part numbers varies depending on YMH (Your Motor Here).  
Contact [help@tolomatic.com](mailto:help@tolomatic.com) for replacement part numbers.

### Disassembly Instructions

1. Remove End Caps (3), and release the tension on the Belt (11) by breaking loose the motor fasteners (1).
2. Remove the RP Cover (8).
3. The Belt (11) can now be removed along with the Motor.
4. Remove both Pulleys (10) and (5) from their respective shafts.
5. Remove the RP Housing (2) from the actuator head by removing the Fasteners (12).

### Assembly Instructions

Note: Apply Loctite #242 to all fasteners upon installation

1. Install RP Housing (2) onto the actuator Head with Fasteners (12).  
**Note:** If the RP housing has a bearing in it do not fully tighten the fasteners at this time. Instead temporarily install the RP cover (8) onto the RP case, positioning the bearing over the leadscrew shaft. Hold the cover in place while tightening all the Fasteners (12) so that the case is snug. Then remove the RP cover and finish tightening the fasteners
2. Install the Motor to the RP Housing with Fasteners (1) and Square Nuts (13). Do not tighten the fasteners at this time.
3. Locate the Belt (11) over the Pulleys (10) and (5) and slide both pulleys over their respective shafts. Tighten each pulley to its shaft with the Collar Clamps (9) and (6).

4. Tension the Belt (11) by pulling the motor away from the drive shaft with the appropriate tension force shown in the chart below. While tensioning, the actuator should be positioned so the weight of the motor does not affect the belt tension. Tighten the Motor Fasteners (1) while the tensioning force is applied to the motor.

SMALLEST SHAFT DIAMETER (Motor or Actuator)		TOTAL WEIGHT TO APPLY	
Inches	mm	lbs	kgs
0.18 to 0.259	4.572 to 6.579	13	5.902
0.260 to 0.499	6.604 to 12.675	22	9.988
0.500 to 0.625	12.7 to 15.875	31	14.074
0.625 and larger	15.875 and larger	40	18.160

Additional tips are found in Tolomatic [Electric Actuator Motor Mounts Technical Note # 3600-4203](#).

5. Verify that there is clearance between the inside of the RP case and each pulley. Verify the pulleys are aligned to each other.
6. Position the Cover (8) in the mating slot of the RP case and install the Fasteners (7) to hold it in place. Take care not to overtighten. If the cover is deflected, it can interfere with the leadscrew.
7. Install both End Caps (3) with the Screws (4) to finalize the assembly.

### Actuator Options

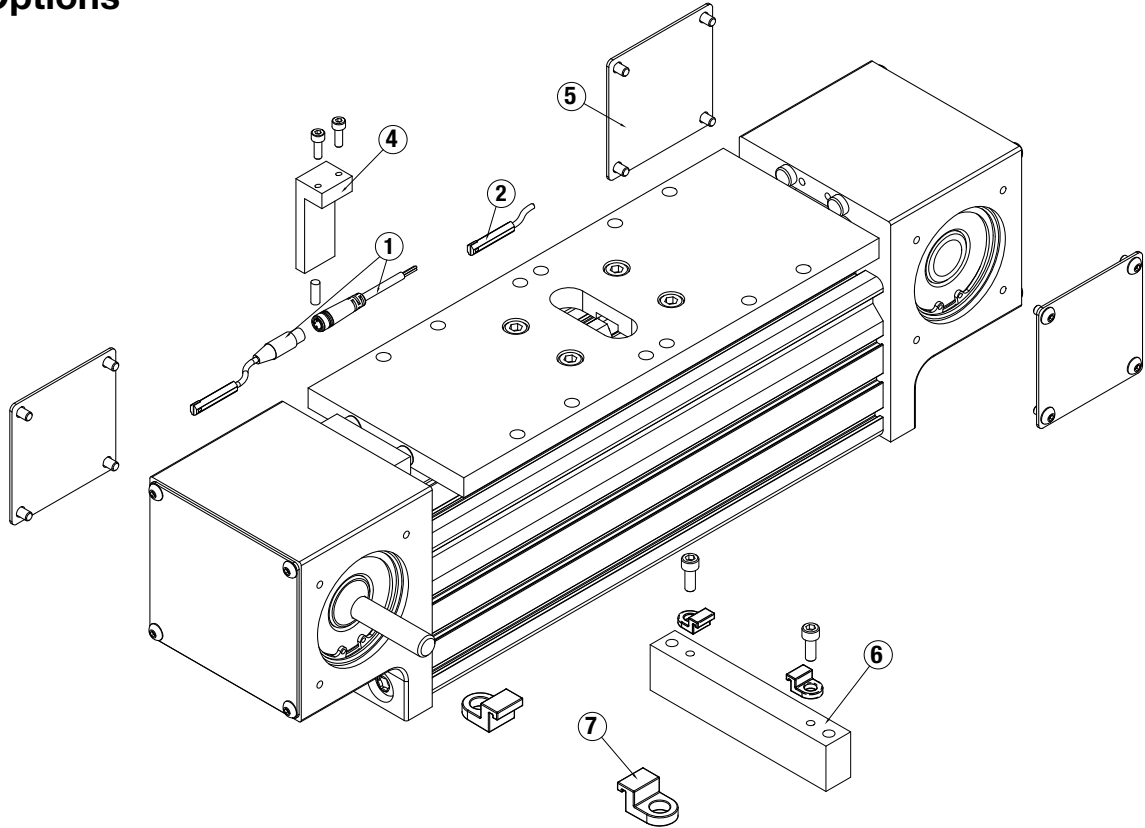

ITEM	PART NO.	DESCRIPTION
4.	<b>8550-9024</b>	<b>MAGNET KIT</b>
	8550-1043	MAGNET BLOCK
	2212-1093	LOW HEAD CAP SCREWS
	8116-1058	MAGNET
5.	<b>8540-9008</b>	<b>SIDE COVER PLATE ASSEMBLY</b>
	8540-1020	COVER PLATE
	8540-1026	BUTTON HEAD CAP SCREW
6.	<b>8363-9016</b>	<b>MOUNTING PLATE KIT</b>
	8363-1031	MOUNTING PLATE
	8163-1050	TUBE CLAMP
	8363-1044	SOCKET HEAD CAP SCREW
7.	<b>8163-9018</b>	<b>TUBE CLAMP KIT</b>
	8163-1050	TUBE CLAMP

**To order service parts switches:**

Switches for MXB include retained mounting hardware and are the same for all actuator sizes and bearing styles

ITEM	CONFIG. CODE	LEAD	NORMALLY	SENSOR TYPE
2.	SWMXB63U <b>R</b> Y	5M (197 IN)	OPEN	REED
1.	SWMXB63U <b>R</b> K	QUICK-DISCONNECT		
2.	SWMXB63U <b>N</b> Y	5M (197 IN)	CLOSED	REED
1.	SWMXB63U <b>N</b> K	QUICK-DISCONNECT		
2.	SWMXB63U <b>T</b> Y	5M (197 IN)	OPEN	SOLID STATE PNP
1.	SWMXB63U <b>T</b> K	QUICK-DISCONNECT		
2.	SWMXB63U <b>K</b> Y	5M (197 IN)	OPEN	SOLID STATE NPN
1.	SWMXB63U <b>K</b> K	QUICK-DISCONNECT		
2.	SWMXB63U <b>P</b> Y	5M (197 IN)	CLOSED	SOLID STATE PNP
1.	SWMXB63U <b>P</b> K	QUICK-DISCONNECT		
2.	SWMXB63U <b>H</b> Y	5M (197 IN)	CLOSED	SOLID STATE NPN
1.	SWMXB63U <b>H</b> K	QUICK-DISCONNECT		

NOTE: When ordering Quick-disconnect, mating female connector is included

### Switch Wiring Diagrams and Label Color Coding (Ce and Rohs Compliant)

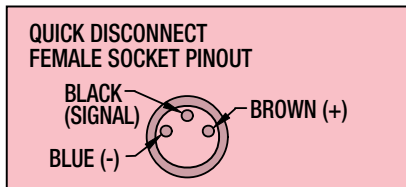
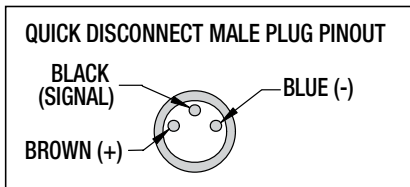
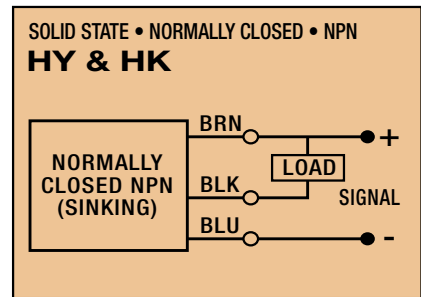
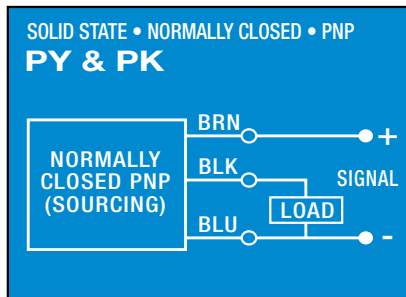
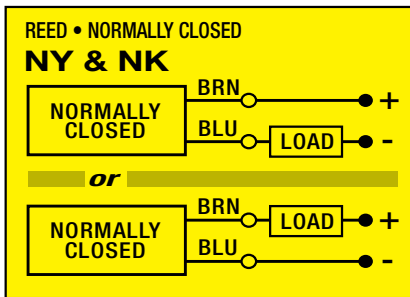
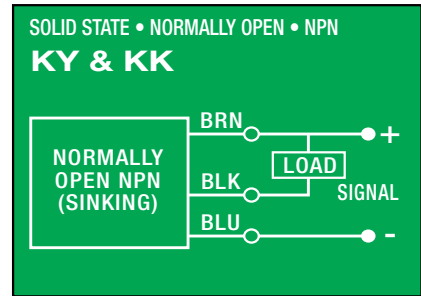
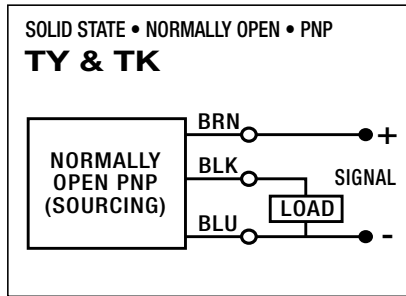
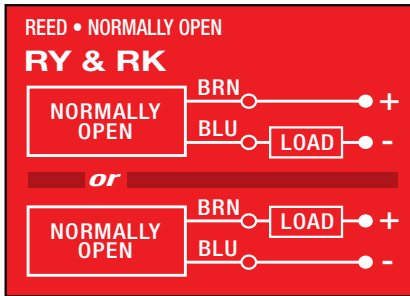

Switches for MX:

- Include retained mounting hardware
- In slot, sit below extrusion profile
- Same for all sizes and bearing styles

#### Switch installation and replacement

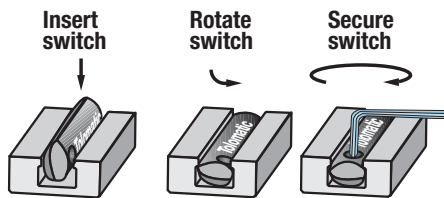

Place switch in side groove on tube at desired location with "Tolomatic" facing outward. While applying light pressure to the switch, rotate it such that the switch is halfway in the groove. Maintaining light pressure, rotate the switch in the opposite direction until the switch is fully inside the groove with "Tolomatic" visible. Re-position the switch to the exact location and lock the switch securely into place by tightening the screw on the switch.

#### Switch Detection point

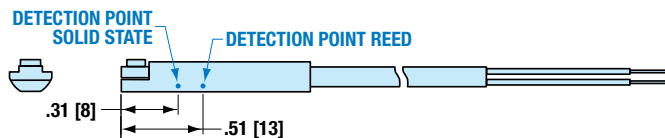

Dimensions in inches [brackets indicate dimensions in millimeters]



3800 County Road 116, Hamel, MN 55340 USA  
<http://www.Tolomatic.com> • Email: [Help@Tolomatic.com](mailto:Help@Tolomatic.com)  
 Phone: (763) 478-8000 • Fax: (763) 478-8080 • Toll Free: 1-800-328-2174

COMPANY WITH  
 QUALITY SYSTEM  
 CERTIFIED BY DNV

All brand and product names are trademarks or registered trademarks of their respective owners. Information in this document is believed accurate at time of printing. However, Tolomatic assumes no responsibility for its use or for any errors that may appear in this document. Tolomatic reserves the right to change the design or operation of the equipment described herein and any associated motion products without notice. Information in this document is subject to change without notice.