

MXP63S Solid Bearing 63mm (2-1/2 inch) Bore

Models:

MXP63STP MXP63SGP MXP63SNP

MXP63SST MXP63SSG MXP63SSN

Both Metric and Inch models

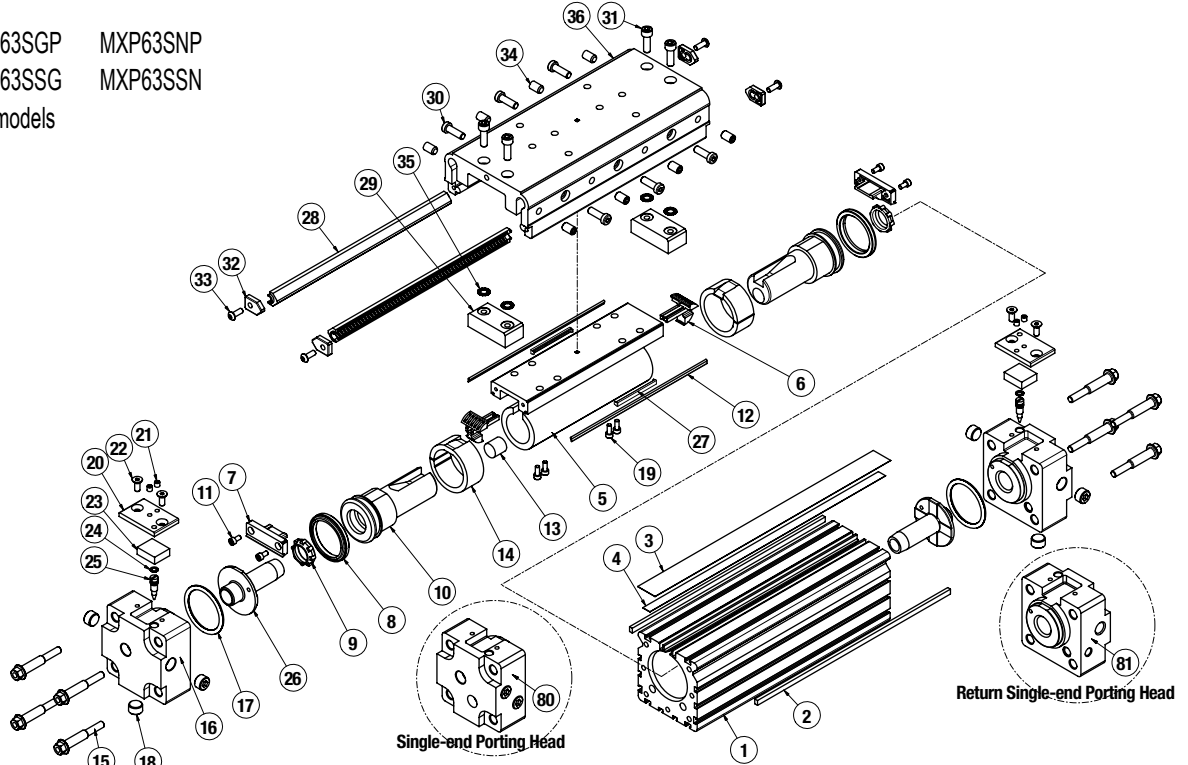

List of Parts

ITEM	PART NO. or CONFIG. CODE	DESCRIPTION	QTY.
1	RTBMXP63S	Replacement Tube (8163-1010) Specify Stroke	A/R
2	NMBMXP63S	Replacement Magnet Band (8163-1019) Specify Stroke	2A/R
13	NDBMXP63S	Replacement Dust Band (8163-1018) Specify Stroke	A/R
14	NSBMXP63S	Replacement Seal Band (8163-1017) Specify Stroke	A/R
5	8163-1512	Piston Bracket (inch)	1
	8163-1012	Piston Bracket (metric)	
16	8163-1007	Band Ramp	2
17	8163-1006	End Cap	2
18	0925-1027	U-Cup	2
19	0925-1012	Cushion Seal	2
10	8163-1004	Piston	2
11	0603-1016	Socket Head Cap Screw	4
12	8163-1059	Wiper	2
13	8140-1058	Magnet	1
14	8163-1005	Wear Ring	2
15	0925-1087	Head Screw (inch)	8
	4925-1047	Head Screw (metric)	
16	8163-1011	Head Assembly, NPT	2
	8163-1046	Head Assembly, BSPT Metric Taper	
	8163-1047	Head Assembly, ISO Metric Parallel	
217	0774-1007	O-Ring	2
218	0920-1029	Pipe Fitting Plug, 3/8 NPT	6
	4920-1029	Pipe Fitting Plug, 3/8-19	
	5920-1006	Pipe Fitting Plug, G 3/8	
19	4910-1004	Low Head Cap Screw	4

ITEM	PART NO. or CONFIG. CODE	DESCRIPTION	QTY.
20	8163-1039	Band Clamp	2
21	0915-1044	Set Screw	4
22	0920-1024	Flat Head Cap Screw	4
23	8163-1038	Band Wedge	2
24	0720-1003	O-Ring	2
25	8163-1065	Needle Screw	2
26	0925-1158	Cushion	2
27	8163-1028	Bearing	2
28	8163-1030	Solid Bearing	2
29	8163-1025	Carrier Spacer Block	2
30	1009-1065	Tension Screw (inch)	6
	8163-1071	Tension Screw (metric)	
31	2230-1044	Low Head Cap Screw	4
32	8163-1031	Bearing End Cap	4
33	2750-1049	Button Head Cap Screw	4
34	8163-1572	Lock Screw (inch)	8
	8163-1072	Lock Screw (metric)	
35	8150-1026	Lock Washer	4
36	8163-1513	Carrier (inch)	1
	8163-1013	Carrier (metric)	
380	8163-9002	Head Assy, NPT, Single-end Porting	1
	8163-9008	Head Assy, BSPT Metric Taper, Single-end Porting	
	8163-9009	Head Assy, ISO Metric Parallel, Single-end Porting	
381	8163-9003	Head Assembly, Return, Single-end Porting	1

¹Parts included in Repair Kits RKMXP63SSK (inch), indicate stroke length in inches
RKMXP63SSM (millimeters), indicate stroke length in millimeters

²Parts included in Head Assemblies (16)

³Part is exclusive to single-end porting option

Drawing repeated for reference

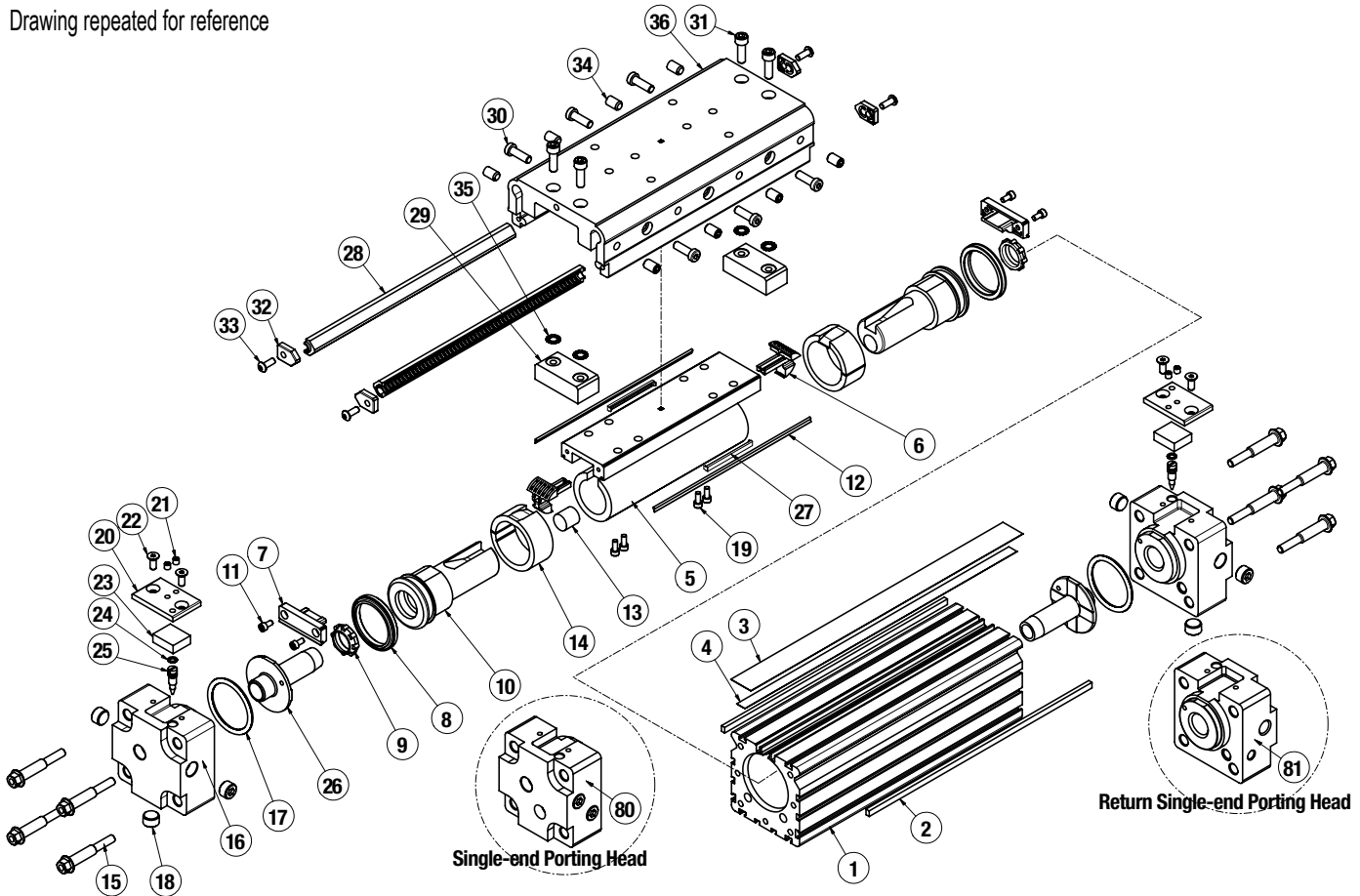

CYLINDER DISASSEMBLY INSTRUCTIONS

Begin with a clean work area. Make sure all replacement parts are available and have no visual damage or defects. The following tools and materials are recommended for proper disassembly and assembly. (Exact wrench sizes will vary depending on cylinder size)

- Allen wrench set (Inch and Metric)
- Small straight edge screwdriver
- Socket wrench & socket set
- Needle nose pliers
- Tin snips
- Razor Blade
- RheoGel TEK664 grease

For best actuator performance it is recommended that the following instructions be read and followed carefully.

1. REMOVE BAND CYLINDER FROM MACHINERY

Remove all mounting hardware and air connections. If present, from the Cylinder Heads (16) and/or Carrier (36).

2. REMOVE CARRIER FROM CYLINDER

Remove Low Head Cap Screws (31), Carrier Retaining Blocks (29), and Lock Washers (35). Remove Tension Screws (30) from the side of the Carrier (36). Turn Lock Screws (34) clockwise a couple of turns on both sides to release pressure on the Bearings and slide Carrier away from Piston Bracket. Remove Button Head Cap Screws (33), Bearing End Caps (32), and Solid Bearings (28). Pull the Carrier off the cylinder.

3. REMOVE BAND CLAMPS

Loosen Screws (21) on Dust Band Clamp (20). Remove Screws (22) from Cylinder Heads (16). Remove Seal Band Clamp (23) from between Dust Band (3) and Seal Band (4). Do not adjust the point Set Screw in the Seal Band Clamp (23). Repeat for other Cylinder Head.

4. REMOVE DUST BAND

Remove End Caps (7) from both ends of the Piston Bracket (5) by removing Screws (11). To remove Dust Band (3), lift one end and pull the Band through the Piston Bracket. The Band is magnetically retained so some resistance will be present when removing.

5. REMOVE HEADS

Remove the four Head Screws (15) to free each Cylinder Head (16). Remove each head by rocking it up and down until the head is free from the Cylinder Tube (1). **DO NOT TWIST!** Remove the O-Ring (17) from both heads with a small straight edge screwdriver.

6. REMOVE SEAL BAND

CAUTION: Sealing Band edges are sharp. Grasp the top and bottom of the Band when removing, not the edges.

Slide Piston Bracket (5) out of the Cylinder Tube (1). Remove the Sealing Band (3) through the slot in the Tube.

7. DISASSEMBLE PISTON BRACKET

Remove Wipers (12) from the Piston Bracket (5). With the small straight edge screwdriver, remove the U-Cups (8) from both

Pistons (10). Remove the Cushion Seal (9) from each Piston. Remove the Pistons (10) by removing Screws (19) then sliding out of Piston Bracket (5). With a small screwdriver, remove the Band Ramps (6) by disengaging the side retaining tabs for each. Keep the Piston Bracket (5) and the two Pistons (10) for reassembly.

CYLINDER ASSEMBLY INSTRUCTIONS

1. CLEAN AND LUBRICATE

Thoroughly clean all components, particularly the Tube (1) Bore, Tube Slot, Sealing Band (4) and Dust Band (3). Thoroughly lubricate the Tube Bore with a thin, uniform layer of RheoGel TEK664 grease.

2. PISTON BRACKET ASSEMBLY

With the Piston Bracket (5) in hand, install the Band Ramps (6), with small end down, so the ends on each side snaps into the hole of the Piston Bracket. Slide the Pistons (10) into the Piston Bracket (5) so the threads on the Piston align with the holes in the Piston Bracket and secure using Screws (19).

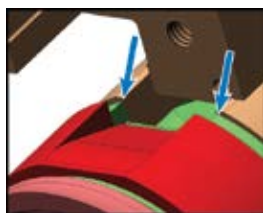

Verify surface of Piston is behind the surface of the Piston Bracket in both places as shown in diagram.

If not aligned properly the Seal Band (4) life may be shortened.

Install new lubricated U-Cups (8) (seal lips facing out), and Cushion Seals (9) (small end facing out).

3. INSTALL SEALING BAND

CAUTION: Metal edges of Sealing Band are sharp. Exercise caution to avoid injury to yourself while installing. Handle Sealing Band with care. Do not damage edges while handling.

Insert Sealing Band (4) into Cylinder Tube (1) by laying the Band out along the length of the actuator and passing it sideways through the slot in Tube. With rubber side facing up (ground side facing down), position the Seal Band so there is enough sticking out the end of the Tube as long as a Piston Assembly.

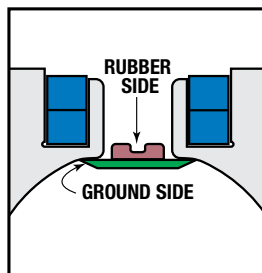

4. INSTALL PISTON ASSEMBLY

Place generous amounts of grease around bore of Tube (1) and on exterior surfaces of both Wear Rings (14) on Pistons (10), U-Cups (8) and Band Ramps (6).

Create a Seal Band Guide Tool by using the 12-inch length of Seal Band included with repair kit (without rubber), or cut a short length of the old Seal Band. (Remove the rubber along the entire length of the Seal Band Guide Tool if needed.) At one inch from one end of the Seal Band Guide Tool, bend slightly upward. The bend helps to guide the Seal Band Guide Tool through the Piston Assembly. Determine which end of the Piston Assembly is going to be inserted into the Tube (1) first. Insert the bent end of the Seal Band Guide Tool into the opposite end of the Piston Assembly. Push the Tool through the opening between the Band Ramp (8) and Wear Ring (14) on the Piston Bracket (5) and stopping when the Tool exits the end of the Piston Assembly.

Place the Seal Band (4) on top of the Seal Band Guide Tool. Insert the Piston Assembly into the Tube (1) until both U-Cups are captured by the bore in the Tube. Do not force the Piston Bracket into the Tube and if the Piston Assembly experiences resistance, use a small

screwdriver to press in the ends of the Band Ramps (6) where entering the Tube. Allow the Seal Band (4) to pass through the Piston Assembly. Once the Seal Band is through the Piston Assembly, pull the Seal Band Guide Tool out of the Piston Assembly. Continue inserting the Piston Assembly into the Tube until the 2nd U-Cup is inserted into the bore of the Tube.

Slide new Wipers (12) into the groove on the Piston Bracket (5) until flush with end. Manually move the Piston Assembly the length of the Tube until the end of the leading U-Cup extends out of the Tube. Wipe off any excess grease from the end of the Piston Assembly and the Tube. Move the Piston Assembly so the U-Cup back into the Tube bore.

Note: If Tube and Piston Assembly were greased properly, excess grease should be present as the Piston exits the end of the Tube. If there is no excess grease present, remove the Piston Assembly and re-grease the Tube, then re-install the Piston Assembly.

5. INSTALL HEADS

CAUTION: Twisting the Head (16) during installation may cut the O-Ring (17) resulting in excessive leakage during operation.

Install new lubricated O-Ring (17) onto each Head (16). Position Piston Assembly near the end of the Tube in which the Head is being installed. Position or trim the Seal Band (4) so 1.25" (31.8mm) is protruding from the end of the Tube (1). Use a razor blade to cut the rubber along the end of the Tube then remove all rubber outside the end of the Tube. Keep the rubber on the Seal Band aligned with the end of the Head (16). Install Head into Tube using a slight up and down rocking motion (not side-to-side or twisting) until the Head is flush with the end of the Tube. Secure Head to Tube by installing Head Screws (15) applying a torque of 190 in-lbs (21.47 N-m). Verify rubber on Seal Band (4) is still aligned with end of Tube. If not, use needle nose pliers to pull on Seal Band until aligned. Place Band Wedge (23) with point of Set Screw down into slot of Head and on top of Seal Band. Push Band Wedge so it is against the end of the Tube. Secure Band Wedge with Band Clamp (20), FHCS (22) and Set Screws (21). Make sure hole in Band Clamp aligns with the Cushion Needle (25) in Head.

Move Piston Assembly to other end of the Tube and repeat the steps above to install the other head. Trim Seal Band with tin snips if needed to achieve 1.25" (31.8mm) from end of Tube. While pulling Seal Band tightly with needle nose pliers, use razor to cut rubber at the end of the Tube. Remove rubber from the end of the Seal Band to the cut just made. Install the Head (16) to the Tube and secure with the Head Screws (15). Use needle nose pliers to pull on the Seal Band removing any slack and aligning the rubber on Seal Band with the end of the Tube. If rubber is past end of Tube, trim excess rubber. If rubber is not up to end of Tube, pull on Seal Band with needle nose pliers to remove slack. Secure Seal Band with Band Clamp, FHCS and Set Screws. Once both ends of the Seal Band are secured, manually move the Piston Assembly the entire length of the Tube two times to see if there is any slack or issues with the Seal Band.

6. INSTALL AND SECURE DUST BAND

Position the Piston Assembly at mid-stroke of the Cylinder. Slide Dust Band (3) through the upper slot of Piston Bracket (5) and lay on top of the cylinder tube slot. Position the Dust Band 1.25" (31.8mm) from each end of Tube. Install End Caps (7) using SHCS (11) into ends of Piston Bracket (5). Loosen Set Screws (21) and FHCS (22) on both ends of the Tube. Slide Dust Band (3) between Band Wedge (23) and Band Clamps (20). Tighten the FHCS then the Set Screws to secure the Dust Band. Move the Piston Assembly to each end of the Tube to verify the Dust Band is positioned properly.

7. CHECK ASSEMBLY

Manually push the Piston Assembly back and forth along the entire length of stroke to make certain that the cylinder is properly assembled before reconnecting to the pneumatic supply. The Piston Assembly should move consistently with minimal friction along the stroke. The Dust Band should not kink at end of stroke. If it does, loosen Set Screws (21) until kinking is eliminated and retighten.

8. INSTALL THE CARRIER

Place Carrier (36) over the top of the reassembled cylinder. Insert the Bearings (28) making sure the Bearings are centered on the Carrier. Install the End Caps (32), and install Screws (33) leaving a 1/8-inch gap between the Screw and the End Cap. Back off on the Lock Screw (34) until there are only 2-3 threads left holding it on.

9. TENSION THE CARRIER

The MX Solid Bearing Carrier will provide best performance when properly adjusted. The Carrier design contains both Tension and Lock Screws. The Tension Screws control the amount of pressure placed on the Carrier Bearings. The Lock Screws lock the Tension Screws in place and provide fine adjustment of the Carrier Bearings.

- Fully loosen all Tension (30) and Lock Screws (34) about 1/2 of a turn so that they are not engaged with the bearing.
- Tighten Tension Screws (30) on both sides of Carrier roughly 1/8 to 1/4 turn clockwise past where the screw starts to feel snug. The Carrier should be very difficult or impossible to move by hand. If not, turn another 1/8 turn until it is difficult to move.
- Next, adjust the Lock Screws (34) on both sides of the Carrier roughly 1/8 to 1/4 turn clockwise past where the Screw starts to engage. The

Carrier will be loose but should not rock sideways. To correct this, loosen Lock Screws (34) about 1/16 of a turn. If the Carrier becomes too snug, tighten the Lock Screws (34) another 1/8 of a turn.

- Ideal Carrier tension is achieved when the Carrier feels snug in relation to the Tube, yet can be moved by hand. No rocking motion should be present. The Carrier should also be loose enough to be moved by hand over the entire length of the actuator. If after this process the Carrier has become too loose, equally adjust all of the Lock Screws with a slight 1/32 turn counter-clockwise. A Carrier that is adjusted too tight will increase the breakaway pressure required for motion and in extreme cases no motion will occur when air is applied.
- Depending on the duty cycle of the application, over time, this process may need to be repeated. Keeping the Carrier in a properly adjusted tension will prolong the life of the MX Bearing System and the actuator itself.**
- Once the proper Carrier tension is achieved, finish tightening the Screws (33) to the Bearing End Caps (32).
 - Center the Carrier (36) over the Piston Bracket (5). Insert the Carrier Retaining Blocks (29) and Lock Washers (35) on both sides of the Carrier. While tightening the Low Head Cap Screws (31), push the Carrier Retaining Blocks (29) inward creating pressure against the Piston Bracket. This should eliminate any backlash between the Carrier and the Piston Bracket.

10. REMOUNT THE CYLINDER ONTO THE MACHINE

- ⚠** Be certain any flow controls are in place and adjusted prior to applying compressed air to the cylinder.

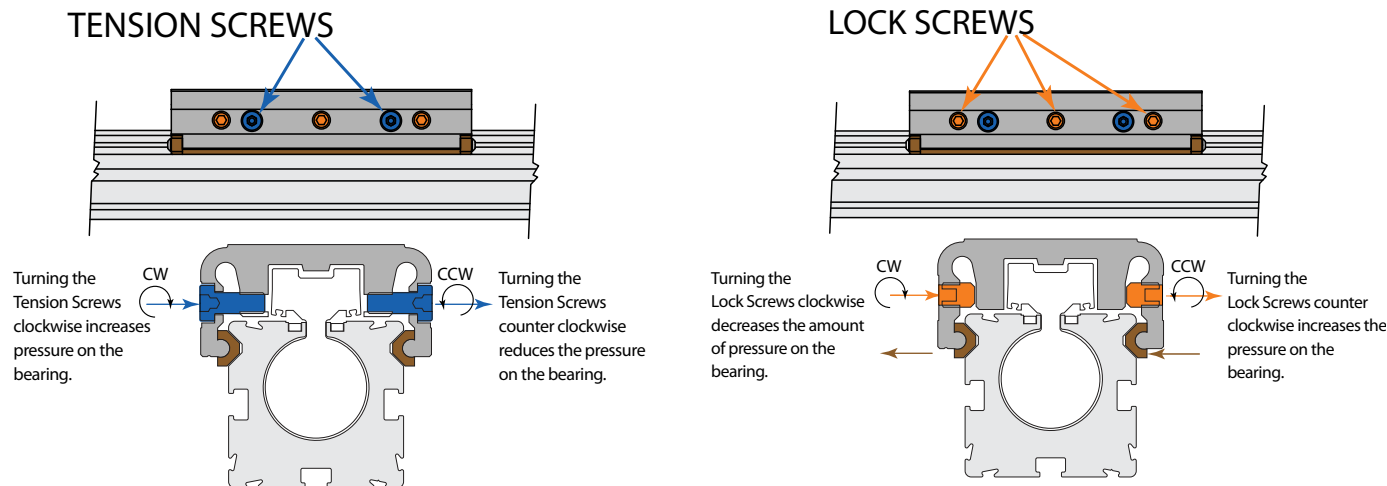

Check out our MX--S carrier adjustment video on the web
<https://youtu.be/LVWPg2gfy0A>

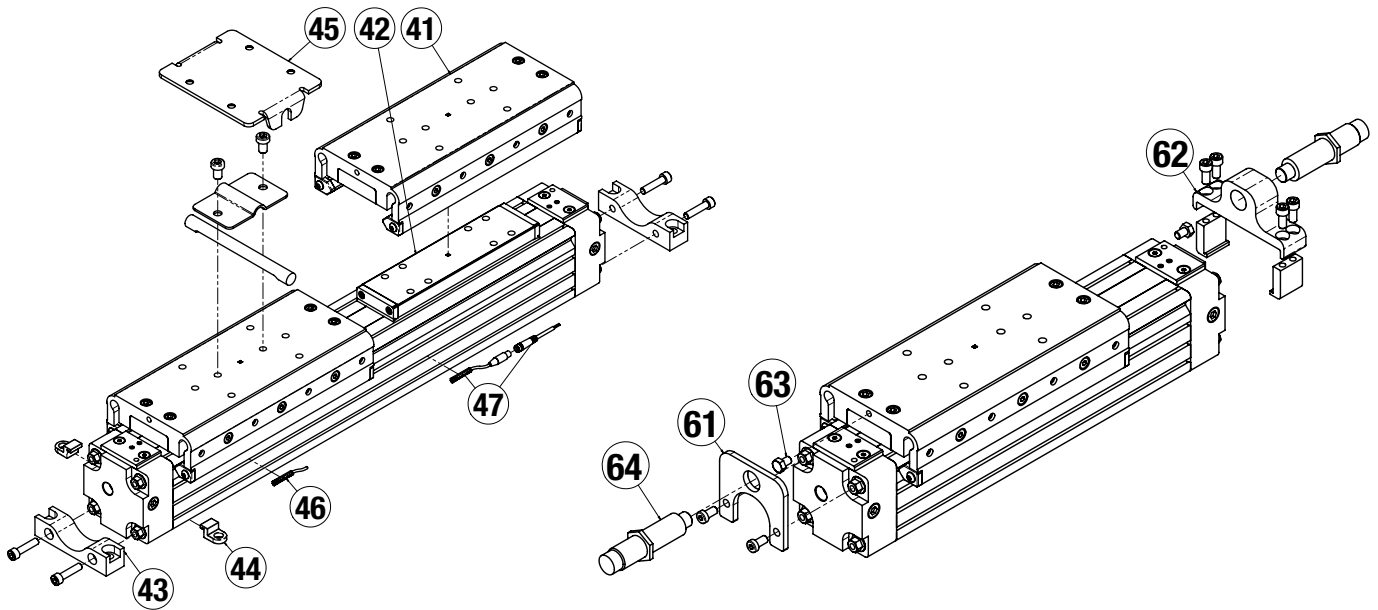

Options - List of Parts

ITEM	PART NO. or CONFIG. CODE	DESCRIPTION
AUXILIARY CARRIER		
41	8163-9505	Auxiliary Carrier Assembly (inch)
	8163-9005	Auxiliary Carrier Assembly (metric)
42	8163-9528	Auxiliary Carrier Piston Bracket Assy (inch)
	8163-9028	Auxiliary Carrier Piston Bracket Assy (metric)
MOUNTING KITS		
43 ²	8163-9519	Foot Mount Kit (inch)
	8163-9019	Foot Mount Kit (metric)
	8163-1055	Foot Mount
	1104-1011	Screw (inch)
	3420-1638	Screw (metric)
44 ¹	8163-9018	Tube Clamp Mounting Kit
	8163-1050	Tube Clamp
45 ³	8163-9536	Floating Mount Kit (inch)
	8163-9036	Floating Mount Kit (metric)
	0925-1054	Clamp, Floating Mount
	8163-1068	Floating Mount Bracket
	8163-1570	Screw (inch)
	8150-1074	Screw (metric)
	8163-1069	Floating Mount Pin
SWITCHES		
46	Switches without Quick-Disconnect Couplers	
	SWMXP63SRY	Reed Switch, SPST Normally Open
	SWMXP63SNY	Reed Switch, SPST Normally Closed
	SWMXP63STY	Solid State Switch, PNP (sourcing) Normally Open
	SWMXP63SKY	Solid State Switch, NPN (sinking) Normally Open
	SWMXP63SPY	Solid State Switch, PNP (sourcing) Normally Closed
	SWMXP63SHY	Solid State Switch, NPN (sinking) Normally Closed

ITEM	PART NO. or CONFIG. CODE	DESCRIPTION
47	Switches with Quick-Disconnect Couplers	
	SWMXP63SRK	Reed Switch, SPST Normally Open
	SWMXP63SNK	Reed Switch, SPST Normally Closed
	SWMXP63STK	Solid State Switch, PNP (sourcing) Normally Open
	SWMXP63SKK	Solid State Switch, NPN (sinking) Normally Open
	SWMXP63SPK	Solid State Switch, PNP (sourcing) Normally Closed
	SWMXP63SHK	Solid State Switch, NPN (sinking) Normally Closed
SHOCK ABSORBERS		
61 ⁴	8163-9520	Fixed Shock Mounting Kit (inch)
	8163-9020	Fixed Shock Mounting Kit (metric)
	8163-1060	Fixed Shock Bracket
	2317-1015	Screw (inch)
	8150-1061	Screw (metric)
62 ⁵	8163-9023	Adjustable Shock Mounting Kit
	8163-1080	Upper Shock Bracket
	8163-1082	Lower Shock Bracket Clamp
	2212-1104	Screw
63	4415-1003	Impact Bolt
64	4920-1068	Light Duty Shock Absorber
	4920-1069	Heavy Duty Shock Absorber

¹ Tube Clamp Kit contains 2 tube clamps.

² Foot Mount Kit contains 1 foot mount and 2 fasteners.

³ Floating Mount Kit contains 1 floating mount, 1 lower strap, 1 pin and 4 fasteners.

⁴ Fixed Shock Mounting Kit contains 1 shock bracket, and 2 fasteners.

⁵ Adjustable Shock Mounting Kit contains 1 shock bracket, 2 bracket clamps, and 4 fasteners.

LUBRICATION AND MAINTENANCE

All Tolomatic MX Band Cylinders are prelubricated at the factory. To ensure maximum cylinder life, the following guidelines should be followed.

1. Filtration

We recommend the use of dry, filtered air in our products. "Filtered air" means a level of 10 Micron or less. "Dry" means air should be free of appreciable amounts of moisture. Regular maintenance of installed filters will generally keep excess moisture in check.

2. External Lubricators (optional)

The factory prelubrication of Tolomatic Band Cylinders will provide optimal performance without the use of external lubrication. However, external lubricators can further extend service life of pneumatic actuators if the supply is kept constant.

Oil lubricators, (mist or drop) should supply a minimum of 1 drop per 20 standard cubic feet per minute to the cylinder. As a rule of thumb, double that rate if water in the system is suspected. Demanding conditions may require more lubricant.

If lubricators are used, we recommend a non-detergent, 20cP @ 140°F 10-weight lubricant. Optimum conditions for standard cylinder operation is +32° to +150°F (+0° to 65.5°C).

NOTE: Use of external lubricators may wash away the factory installed lubrication. External lubricants must be maintained in a constant supply or the results will be a dry actuator prone to premature wear.

3. Sanitary Environments

Oil mist lubricators must dispense "Food Grade" lubricants to the air supply. Use fluids with ORAL LD50 toxicity ratings of 35 or higher such as Multitherm® PG-1 or equivalent. Demanding conditions can require a review of the application.

4. Cushion Adjustment

Adjust the Cushion Needles in the Cylinder Heads carefully to obtain optimum deceleration for your particular application. If there are questions on proper adjustment, please consult Tolomatic.

SWITCH WIRING DIAGRAMS AND LABEL COLOR CODING (CE and RoHS Compliant)

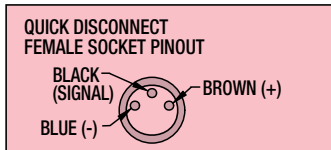
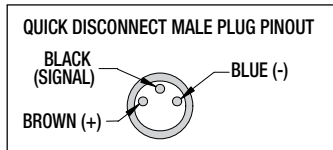
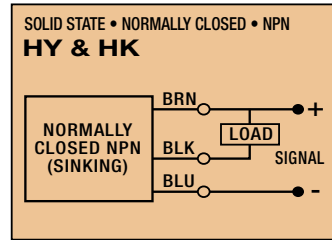
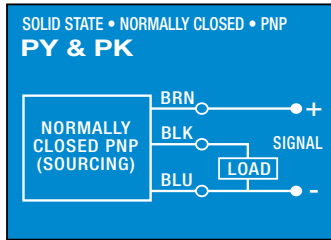
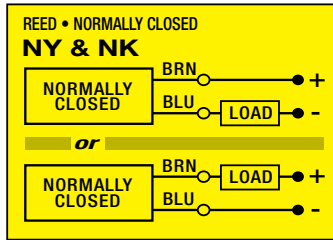
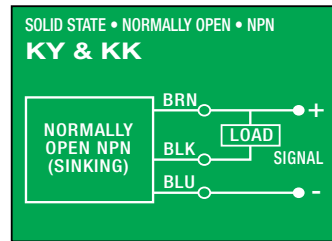
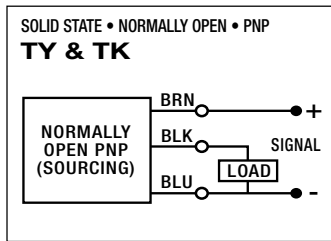
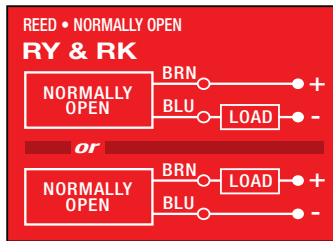

Switches for MX:

- Include retained mounting hardware
- In slot, sit below extrusion profile
- Same for all sizes and bearing styles

SWITCH INSTALLATION AND REPLACEMENT

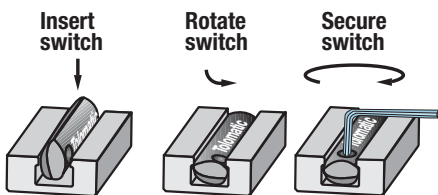

Place switch in side groove on tube at desired location with "Tolomatic" facing outward. While applying light pressure to the switch, rotate the switch halfway into the groove. Maintaining light pressure, rotate the switch in the opposite direction until the switch is fully inside the groove with "Tolomatic" visible. Re-position the switch to the exact location and lock it securely into place by tightening the screw on the switch.

SWITCH DETECTION POINT

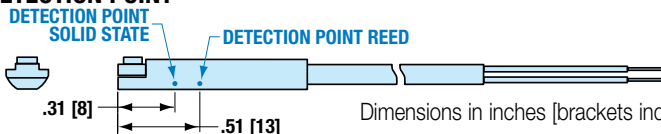

Dimensions in inches [brackets indicate dimensions in millimeters]



3800 County Road 116, Hamel, MN 55340
 http://www.Tolomatic.com • Email: Help@Tolomatic.com
 Phone: (763) 478-8000 • Fax: (763) 478-8080 • Toll Free: 1-800-328-2174



Information furnished is believed to be accurate and reliable. However, Tolomatic assumes no responsibility for its use or for any errors that may appear in this document. Tolomatic reserves the right to change the design or operation of the equipment described herein and any associated motion products without notice. Information in this document is subject to change without notice.