

# TruTrack Belt-Drive Actuator

TKB75

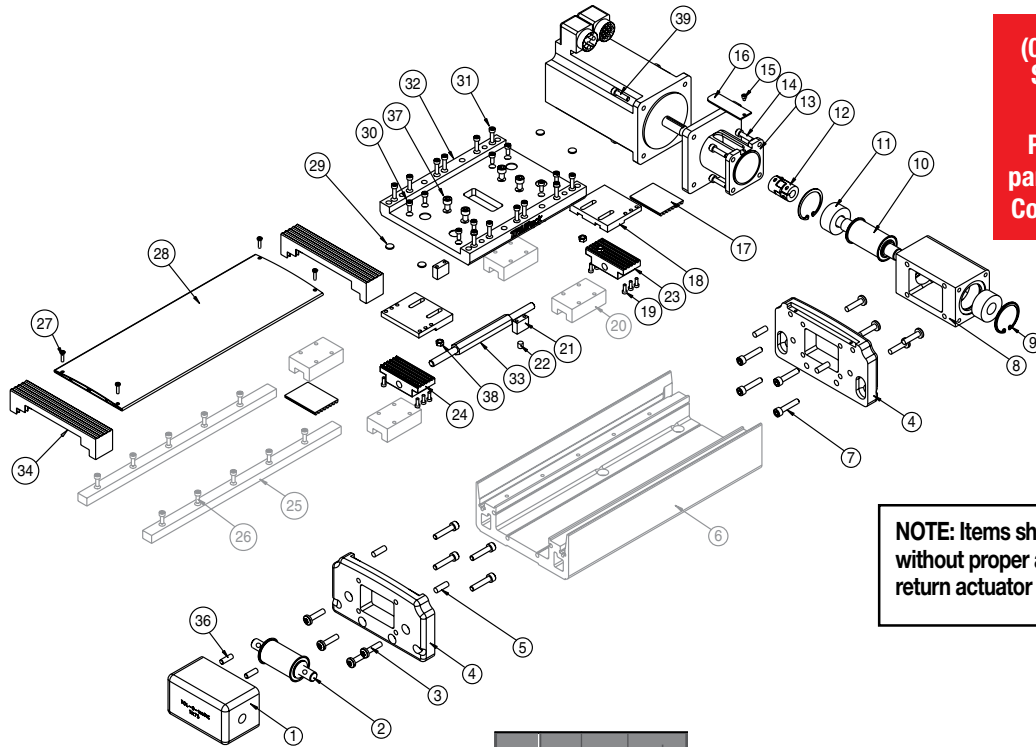

**(09/01/2021) DISCONTINUED PRODUCT STYLE OR SIZE. PARTS SHEET IS FOR REPAIR INSTRUCTIONS ONLY.**

**Parts listing is for reference only. All parts listed are limited to stock on hand. Contact Tolomatic regarding availability.**

**NOTE: Items shaded cannot be field installed without proper assembly fixtures. For repair, return actuator to Tolomatic.**

### List of Parts

ITEM	Part No. or CONFIG. code	DESCRIPTION				
			MRV31,32,33	MRS341,342,343	GEAR HEAD34	REVERSE PARALLEL
1	0604-2021	ADAPTER, IDLE HEAD	1	1	1	1
2	0604-9300	IDLE PULLEY ASSEMBLY	1	1	1	1
3	0604-1025	SCREW PAN M6 x 25mm	8	8	8	8
4	0604-2007	HEAD, DRIVE, IDLE	2	2	2	2
5	0602-1049	BUMPER	4	4	4	4
6	0604-2001	BASE	1	1	1	1
7	0604-2029	SHCS, M6 x 30mm	8	8	8	8
8	0604-2020	ADAPTER, DRIVE HEAD	1	1	1	1
9	2317-1083	RET. RNG, 5002-137.	2	2	2	2
10	0604-9820	STUB-SHAFT	1	1		
	0604-9821	STUB-SHAFT, GH34			1	
	0604-9822	STUB-SHAFT, RP.				1
11	0602-2031	BEARING, I.D. .56	2	2	2	2
12	3600-9252	COUPLER KIT	1		1	
	3600-9253	COUPLER KIT		1		
13	0603-2033	SPACER	1	1	1	
14	2212-1097	SHCS, M5 x 16, SST	4	4	4	
15	0601-2041	SHCS, M3 x 4, SST	1	1	1	
16	0603-2035	SPACER COVER	1	1	1	
17	0604-2049	BELT, TIMING, MACHINED	1	1	1	1
18	0604-2085	BELT CLAMP, UPPER	2	2	2	2
19	0604-2088	SHCS, M3 x 12mm	12	12	12	12

ITEM	Part No. or CONFIG. code	DESCRIPTION				
			MRV31,32,33	MRS341,342,343	GEAR HEAD34	REVERSE PARALLEL
20	0602-1006	BLOCK, THK LINEAR	4	4	4	4
21	0604-1013	MAGNET BLOCK	2	2	2	2
22	2224-1016	MAGNET ROD	2	2	2	2
23	0604-2086	CLAMP, BELT, LOWER, RIGHT HAND	1	1	1	1
24	0604-2087	CLAMP, BELT, LOWER, LEFT HAND	1	1	1	1
25	0604-1033	RAIL, MACHINE	2	2	2	2
26	2212-1093	SHCS, M4 x 12mm	AR	AR	AR	AR
27	0603-1036	SCREW BUTTON HEAD, M3 x 10mm	4	4	4	4
28	0604-1003	COVER	1	1	1	1
29	0601-2090	PAD	4	4	4	4
30	2212-1092	SHCS, M4 x 10mm	12	12	12	12
31	0602-1027	SHCS, M4 x 16mm	12	12	12	12
32	0604-2084	CARRIER	1	1	1	1
33	0603-2088	SCREW, TENSIONING	1	1	1	1
34	0603-9830	BELLOWS KIT	1	1	1	1
35	0604-2031	SCREW, HEX, M8 x 50 mm	2	2	2	2
36	2317-1062	SCREW, SET, 1/4-20 x .38"	2	2	2	2
37	2212-1097	SHCS, M5 x 16, SST	4	4	4	4
38	0603-2089	NUT, HEX, MS	4	4	4	4
39	2212-1096	SHCS		4		
	2212-1097	SHCS, M5 x 12, SST	4		4	

(09/01/2021) DISCONTINUED PRODUCT  
STYLE OR SIZE. PARTS SHEET IS FOR  
REPAIR INSTRUCTIONS ONLY.

Parts listing is for reference only. All  
parts listed are limited to stock on hand.  
Contact Tolomatic regarding availability.

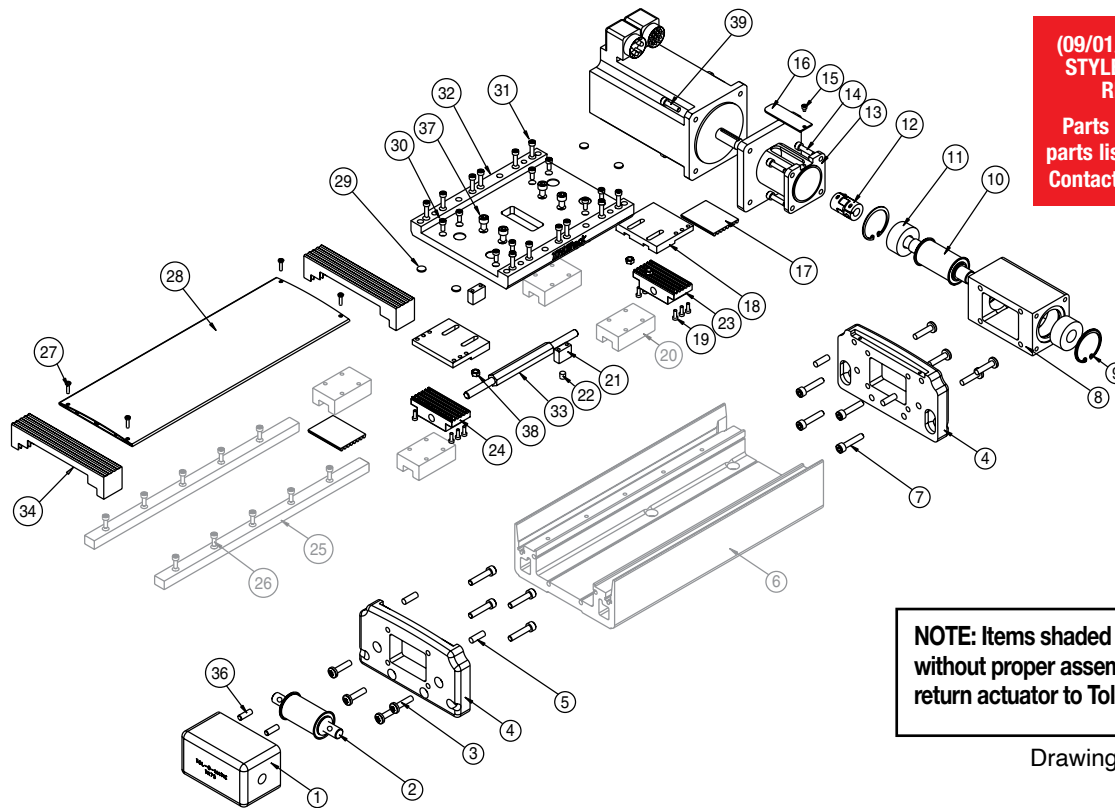

**NOTE:** Items shaded cannot be field installed  
without proper assembly fixtures. For repair,  
return actuator to Tolomatic.

Drawing repeated for reference

### General Cylinder Disassembly Instructions

Begin with a clean work area. Be sure all replacement parts present and have no visual damage or defects. The following tools are recommended for proper disassembly and assembly:

- \* Metric Allen Wrench Set
- \* SAE Allen Wrench Set
- \* Torx bit set
- \* Metric Socket Set
- \* Metric Combination Wrench Set

1. **Remove Carrier and Head Adapters.** Remove Cover Screws(27) and remove the Cover(28). Remove all Cap Screws(30) that attach Carrier(32) to THK Blocks(20). Remove Cap Screws(37) that attach Carrier to Belt Clamps(18). Lift carrier from THK Blocks. Remove the belt tensioning screw. Remove Cap Screws(7) to remove Head Adapters(1,8).
2. **Remove Belt and Heads.** Remove Cap Screws(19) to release the Belt Clamps(19,23,24). The Belt(17) can now be removed from the assembly. Remove Cap Screws(3) to allow the Heads(4) to be removed. The THK blocks to are now free to come off the rails if need be. Note that the balls in the bearing are contained within the bearing.
3. **Head Adapter Disassembly.** The drive shaft assembly is a slip fit in the drive head adapter. Removal of the Snap Rings(9) will allow the Bearings(11) and Shaft(10) to slide out. There are 2 set screws that hold the Idle Shaft(2) in the idle head adapter(1). Remove these screws and the shaft can be removed. The Idle Pulley Assy(2) has bearings pressed into the pulley. Contact factory about replacement assy.

### General Cylinder Assembly Instructions

1. **Head Adapter Assembly.** On the drive head adapter install the 1st Snap Ring(9) on the side of the head that will have the stub shaft exposed. Slide in the pulley/bearing assembly into the adapter in proper orientation, (left or right). Install the 2nd snap ring. Pack the idle bearing with Mobil HP grease. Insert the idle pulley shaft part way into the idle head adapter. Locate a spacer over the shaft and then position the pulley/bearing assembly over the shaft. Slide the shaft through the bearing and locate another spacer between the pulley and inside of the adapter housing. With the shaft ends flush with the outside of the head adapter, tighten the set screws into the housing to lock the shaft in position. Notice the pilot's in the shaft for the set screws.
2. **Install Heads, Carrier and Belt.** Attach the Heads to the Base(6). Feed belt through each of the Heads, and through the pulleys in each Head Adapters. Attach each Head Adapter to the head. Attach the Belt Clamps to the Belt with the cap screws, and start the tension screw into each of the Belt Clamps. Position Hex Nut's (38) in the slots of the belt clamp and secure in place with a piece of tape across bottom of nut's and belt clamp. Position the carrier over the belt clamps and attach carrier to the belt clamps with SHCS through the slots in carrier and remove the tape from bottom of belt clamp. Position the Carrier on the THK blocks and attach with Cap Screws. Torque to 50 in-lbs.
3. **Tension Belt.** To measure the belt tension, position the edge of the carrier that is nearest the head, 6" from the inside edge of the head. (Either end of actuator, does not matter). Locate a force gage on the belt, 2" from the inside edge of the head. Deflect the belt in either direction 3/8". The force gage should read between 14 and 18 lbs. Adjust the tension screw until this is obtained.
4. When proper belt tension is attained tighten the belt clamps to the carrier with Cap Screws(37).
5. **Install Cover.** Attach the Cover to the unit with Cap Screws(27).

**Reduction Drive**

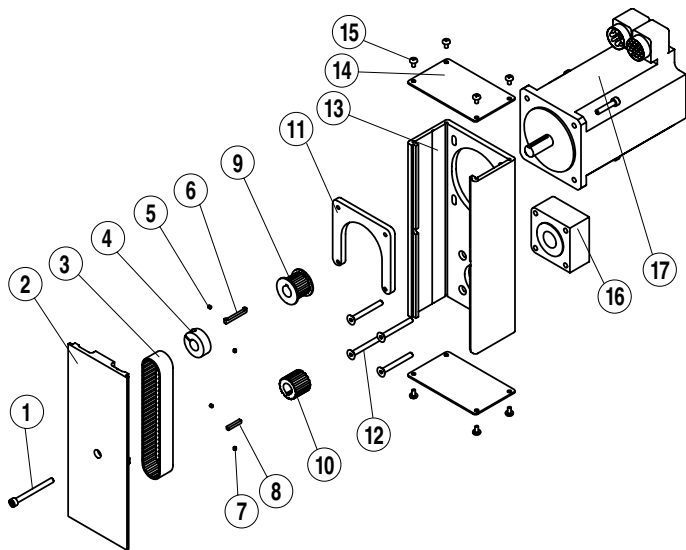

**(09/01/2021) DISCONTINUED PRODUCT STYLE OR SIZE. PARTS SHEET IS FOR REPAIR INSTRUCTIONS ONLY.**

**Parts listing is for reference only. All parts listed are limited to stock on hand. Contact Tolomatic regarding availability.**

**List of Parts**

ITEM	Part No. or CONFIG. code	DESCRIPTION	REDUCTION			
			1:1	2:1	MRV31_32,33	MRS341_342,343
1	3420-1639	SHCS, M5 X 0.8, 55 MM LONG, SST	1	1	1	1
2	0602-1615	COVER	1	1	1	1
3	2133-1025	TIMING BELT	1	1		
	2164-1007	TIMING BELT, 375-5M-19			1	1
4	2312-1005	CLAMP COLLAR, Ø.500		1		1
5	4415-1015	SET SCREW, M3 X 0.5 X 3 MM LONG	2		2	
6	2132-1021	KEY, SPECIAL, .125 X .125	1		1	
7	4415-1015	SET SCREW, M3 X 0.5 X 3 MM LONG	2	2	2	2
8	2100-1021	KEY	1	1		
	1004-7706	KEY, .125 X .125 X 1.00 LONG			1	1
9	2132-1002	PULLEY	1		1	
	0602-9850	PULLEY, 16 TEETH, 19 MM WIDTH			1	1
10	0603-1053	PULLEY	1	1		
	0603-1054	PULLEY, 32 TEETH, 19 MM WIDTH			1	1
11	0602-1057	PLATE, MOTOR	1	1	1	1
12	0603-2031	SFHCS, M5 X 0.8 X 45 MM LONG, SST	4	4	4	4
13	0602-1607	HOUSING	1	1	1	1
14	0602-1602	END CAP	2	2	2	2
15	0601-1625	SCREW, #6 X .25, SELF-TAPPING, SST	8	8	8	8
16	0603-2054	SPACER,TKB50/75	1	1	1	1
17	2212-1099	SHCS, M5 X 0.8 X 25 MM LONG, SST	4	4	4	4

**Reverse Parallel Disassembly Instructions:**

1. Remove End Caps (14). Release tension on belt by breaking loose the motor fasteners (17).
2. Remove RP Cover (2).
3. Remove both drive pulley (9) and driven pulley (10) from their respective shafts. The belt (3) will come off with the pulleys.
4. Remove motor fasteners (17) to remove motor from RP case.
5. Remove the RP case (13) from the head by removing fasteners (12).

**Reverse Parallel Assembly Instructions:**

\*Apply Loctite #242 to all fasteners upon installation

1. Install RP case (14) to the head with cap screws (13).
2. Install the motor to the RP case with fasteners (18). Do not tighten the fasteners at this time.
3. Locate the belt (3) over the pulleys and slide the drive (9) and driven (10) pulleys over their respective shafts. Tighten each pulley to its shaft with either trantorque or collar clamp. If trantorque, utilize torque wrench to apply appropriate torque. 1/2" hex on trantorque apply 75 in-lbs. 5/8" hex on trantorque apply 100 in-lbs.
4. Verify that there is clearance between the inside of the RP case and each pulley. Verify that the pulleys are aligned to each other.
5. Position the cover (2) in mating slot of the RP case and install the SHCS (1) to hold in place.
6. Tension the belt by pulling the motor away from the drive shaft with the appropriate force from literature # 3600-4212. Tighten the motor fasteners while this force is applied to the motor.

Motor Frame	Tension Force
MRB23, MRS23	10 lbs
MRV23, MRS34	20 lbs
MRV34, MRB34	30 lbs

7. Install both end caps (15) with the screws (16) to finalize assembly.

Christo-Lube® is a registered trademark of Lubrication Technology, Inc., www.lubricationtechnology.com

Loctite® is a registered trademark of the Loctite Corporation, www.loctite.com

Mobil grease® HP is a registered trademark of Mobil Oil Corporation, www.mobil.com

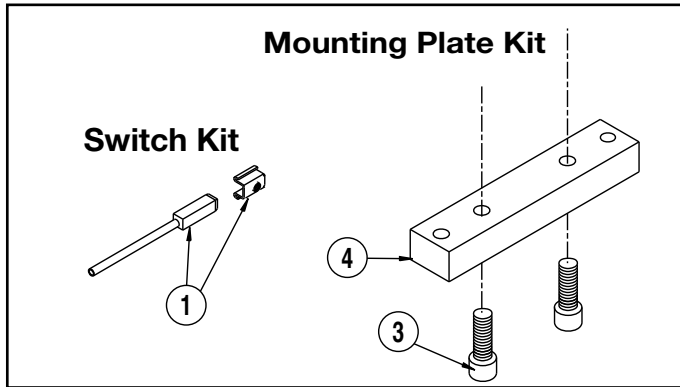

**Universal Switch Wiring Diagrams and Label Color Coding**

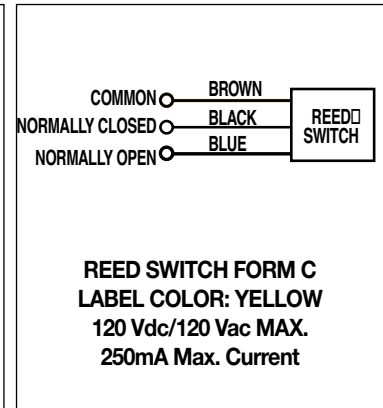
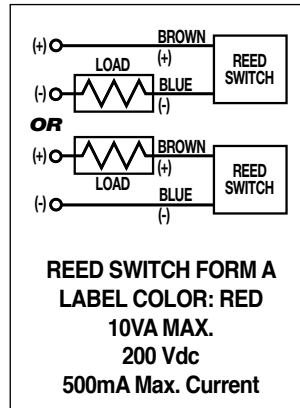

**List of Parts**

Item	Part No. or CONFIG. code	Description	QTY.
<b>SWITCH KIT</b>			
1	SWTKB75RT	SWITCH, REED, FORM A, 5M WIRE	AR
	SWTKB75BT	SWITCH, REED, FORM C, 5M WIRE	AR
	SWTKB75TT	SWITCH, SOURCE, HALL, 5M WIRE	AR
	SWTKB75KT	SWITCH, SINKING, HALL, 5M WIRE	AR
NOTE: Switch bracket with set screw is included			
<b>MOUNTING PLATES</b>			
3	0604-1038	SHCS M6 X 20	2
4	0604-1080	MOUNTING PLATE	1

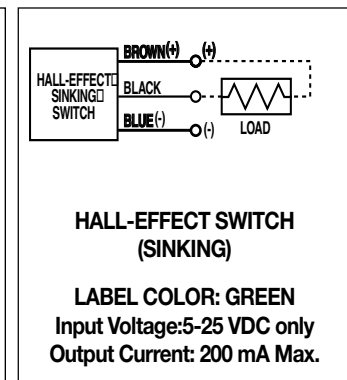
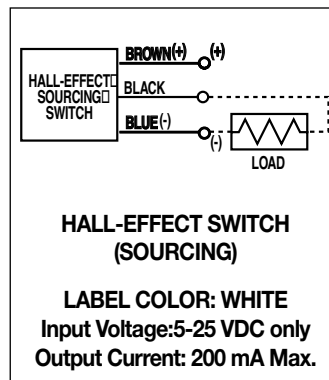

**OPTIONAL ACCESSORY ASSEMBLY INSTRUCTIONS**

- MOUNTING PLATES.** Mounting Plates should be secured at the required distances determined for the application to prevent tube deflection. Apply Loctite #242 to Screws and secure Mounting Plates to tube, aligning holes in tube with holes in Mounting Plates.
- SWITCHES**  
**NOTE:** Form A Reed Switches should not be used in TTL logic circuits. A voltage drop caused by the L.E.D. indicator will result. For applications where TTL circuits are used, please contact the factory.

**WARNING:** An ohmmeter is recommended for testing Reed Switches. NEVER use an incandescent light bulb as a high current rush may damage the switch.

Reed switches are only recommended for signalling position, not directly powering solenoids. For shifting a solenoid, a relay or resistor is recommended between it and the Reed Switch. Switch ratings must not be exceeded at any time.

**NOTE:** The side of the switch with the groove indicates the sensing surface. This must face toward the magnet.

**TO ORDER RETROFIT KITS:**

SW (then the model number and base size, and code for type of switch needed).

**EXAMPLE: SWTK75BT**

Where **SW** is the switch kit, **TK** is the model, **75** is the 3" size, and **BT** is a Form C Reed Switch with 5-meter lead.

<b>SWITCH TYPE CODE</b>	
<b>BT</b>	(Form C Reed Switch with 5-meter lead)
<b>RT</b>	(Form A Reed Switch with 5-meter lead)
<b>KT</b>	(Hall-effect Switch (Sinking) 5-meter lead)
<b>TT</b>	(Hall-effect Switch (Sourcing) 5-meter lead)

**(09/01/2021) DISCONTINUED PRODUCT STYLE OR SIZE. PARTS SHEET IS FOR REPAIR INSTRUCTIONS ONLY.**

**Parts listing is for reference only. All parts listed are limited to stock on hand. Contact Tolomatic regarding availability.**



3800 County Road 116, Hamel, MN 55340  
 http://www.Tolomatic.com • Email: Help@Tolomatic.com  
 Phone: (763) 478-8000 • Fax: (763) 478-8080 • Toll Free: 1-800-328-2174

**COMPANY WITH QUALITY SYSTEM CERTIFIED BY DNV GL = ISO 9001 =**

Information furnished is believed to be accurate and reliable. However, Tolomatic assumes no responsibility for its use or for any errors that may appear in this document. Tolomatic reserves the right to change the design or operation of the equipment described herein and any associated motion products without notice. Information in this document is subject to change without notice.