

TruTrack Screw-Drive Actuator

TKS25

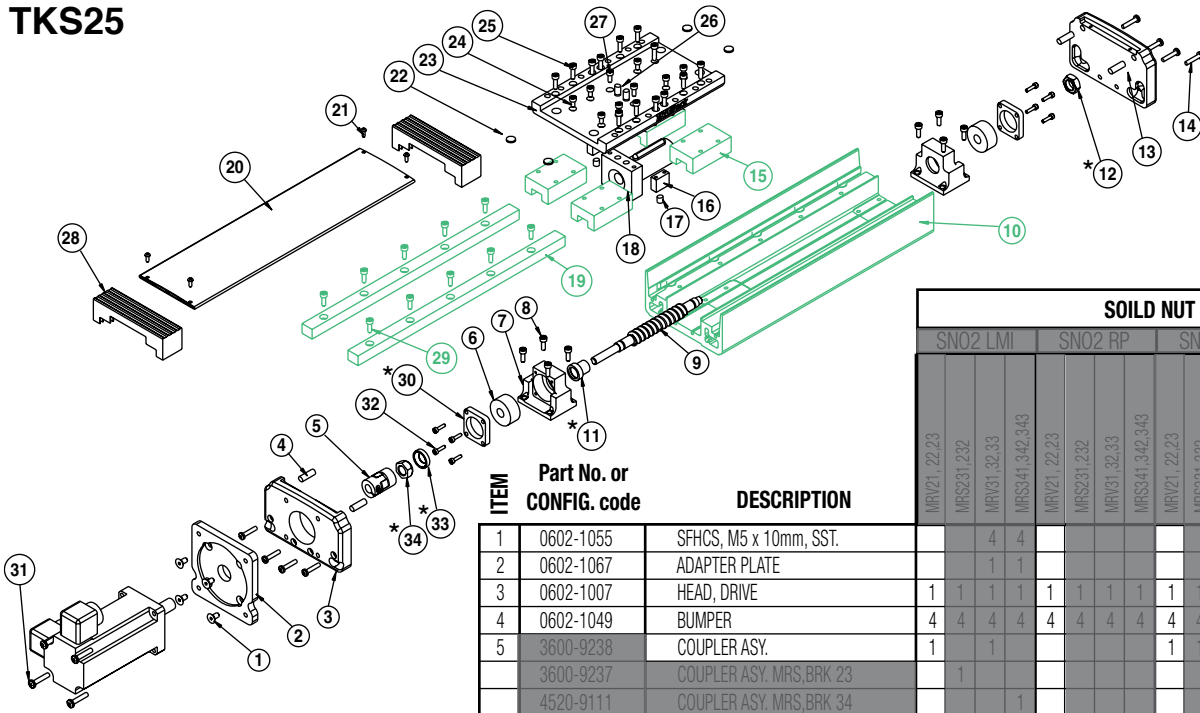

NOTE: Items shaded cannot be field installed without proper assembly fixtures. For repair, return actuator to Tolomatic

*Not backward compatible with units manufactured before 08/01/2003

(09/01/2021) DISCONTINUED PRODUCT STYLE OR SIZE. PARTS SHEET IS FOR REPAIR INSTRUCTIONS ONLY.

Parts listing is for reference only. All parts listed are limited to stock on hand. Contact Tolomatic regarding availability.

ITEM	Part No. or CONFIG. code	DESCRIPTION	SOILD NUT																		
			SNO2 LMI				SNO2 RP				SNO2 GH				SNO2 BRK						
1	0602-1055	SFHCS, M5 x 10mm, SST.			4	4								4	4					4	4
2	0602-1067	ADAPTER PLATE			1	1								1	1					1	1
3	0602-1007	HEAD, DRIVE	1	1	1	1	1	1	1	1	1	1	1	1	1	1	1	1	1	1	1
4	0602-1049	BUMPER	4	4	4	4	4	4	4	4	4	4	4	4	4	4	4	4	4	4	4
5	3600-9238	COUPLER ASY.			1								1	1	1	1	1			1	
	3600-9237	COUPLER ASY. MRS,BRK 23			1															1	
	4520-9111	COUPLER ASY. MRS,BRK 34					1														1
6	0602-1025	BEARING, DBL ROW ANGULAR	2	2	2	2	2	2	2	2	2	2	2	2	2	2	2	2	2	2	2
7	0602-1014	BEARING BLOCK	2	2	2	2	2	2	2	2	2	2	2	2	2	2	2	2	2	2	2
8	2212-1093	SHCS, M4 x 12mm, SST	8	8	8	8	8	8	8	8	8	8	8	8	8	8	8	8	8	8	8
9	0602-1642	Lead Screw	1																1		
	0602-1645	SNO2, MRS23			1															1	
	0602-1648	SNO2, MRV34/MRS34			1	1														1	1
	0602-1651	SNO2, GH23										1	1								
	0602-1655	SNO2, GH34												1	1						
	0602-1658	SNO2, RP, 23 FRAME					1	1													
	0602-1667	SNO2, RP, 34 FRAME							1	1											
10	0602-1001	BASE, MACHINED	1	1	1	1	1	1	1	1	1	1	1	1	1	1	1	1	1	1	1
*11	0602-1641	TAPER SLEEVE	1	1	1	1	1	1	1	1	1	1	1	1	1	1	1	1	1	1	1
*12	0602-1670	HEX NUT	1	1	1	1	1	1	1	1	1	1	1	1	1	1	1	1	1	1	1
13	0602-1008	HEAD, IDLE	1	1	1	1	1	1	1	1	1	1	1	1	1	1	1	1	1	1	1
14	0602-1028	SCREW, PAN M4 x 20mm, SST	8	8	8	8	8	8	8	8	8	8	8	8	8	8	8	8	8	8	8
15	0602-1006	BLOCK, THK LINEAR	4	4	4	4	4	4	4	4	4	4	4	4	4	4	4	4	4	4	4
16	0602-1013	MAGNET BLOCK	2	2	2	2	2	2	2	2	2	2	2	2	2	2	2	2	2	2	2
17	2224-1016	MAGNET ROD	2	2	2	2	2	2	2	2	2	2	2	2	2	2	2	2	2	2	2
18	0602-9201	ASSY. CONNECTOR ACME NUT	1	1	1	1	1	1	1	1	1	1	1	1	1	1	1	1	1	1	1
19	0602-1036	RAIL, MACHINED	2	2	2	2	2	2	2	2	2	2	2	2	2	2	2	2	2	2	2
20	0602-1003	COVER, MACHINED	1	1	1	1	1	1	1	1	1	1	1	1	1	1	1	1	1	1	1
21	0601-1095	SCREW, BUTTON M3 x 8mm, SST	4	4	4	4	4	4	4	4	4	4	4	4	4	4	4	4	4	4	4
22	0601-2090	PAD	4	4	4	4	4	4	4	4	4	4	4	4	4	4	4	4	4	4	4
23	0602-1004	CARRIER	1	1	1	1	1	1	1	1	1	1	1	1	1	1	1	1	1	1	1
*24	0602-1030	SHCS, M4 x 8mm, SST	8	8	8	8	8	8	8	8	8	8	8	8	8	8	8	8	8	8	8
25	0604-1028	SHCS, M4 x 14mm, SST	12	12	12	12	12	12	12	12	12	12	12	12	12	12	12	12	12	12	12
26	0603-1070	PIN, DOWEL	2	2	2	2	2	2	2	2	2	2	2	2	2	2	2	2	2	2	2
27	2212-1092	SHCS, M4 x 10mm SST	2	2	2	2	2	2	2	2	2	2	2	2	2	2	2	2	2	2	2
28	0602-9830	BELLOWS KIT	1	1	1	1	1	1	1	1	1	1	1	1	1	1	1	1	1	1	1
29	2212-1093	SHCS, M4 X 12, SST	AR	AR	AR	AR	AR	AR	AR	AR	AR	AR	AR	AR	AR	AR	AR	AR	AR	AR	AR
*30	0602-2095	CLAMP, BEARING	2	2	2	2	2	2	2	2	2	2	2	2	2	2	2	2	2	2	2
31	2212-1098	Screw	4											4	4	4	4	4	4	4	4
	2212-1097	SHCS, M5 x 16, SST			4																
	2212-1096	SHCS, M5 x 12, SST			4	4															
32	2212-1112	SHCS, M3 x 12, SST	8	8	8	8	8	8	8	8	8	8	8	8	8	8	8	8	8	8	8
*33	1124-1092	SPHERICAL WASHER	1	1	1	1	1	1	1	1	1	1	1	1	1	1	1	1	1	1	1
34	1124-1082	SPHERICAL NUT	1	1	1	1	1	1	1	1	1	1	1	1	1	1	1	1	1	1	1

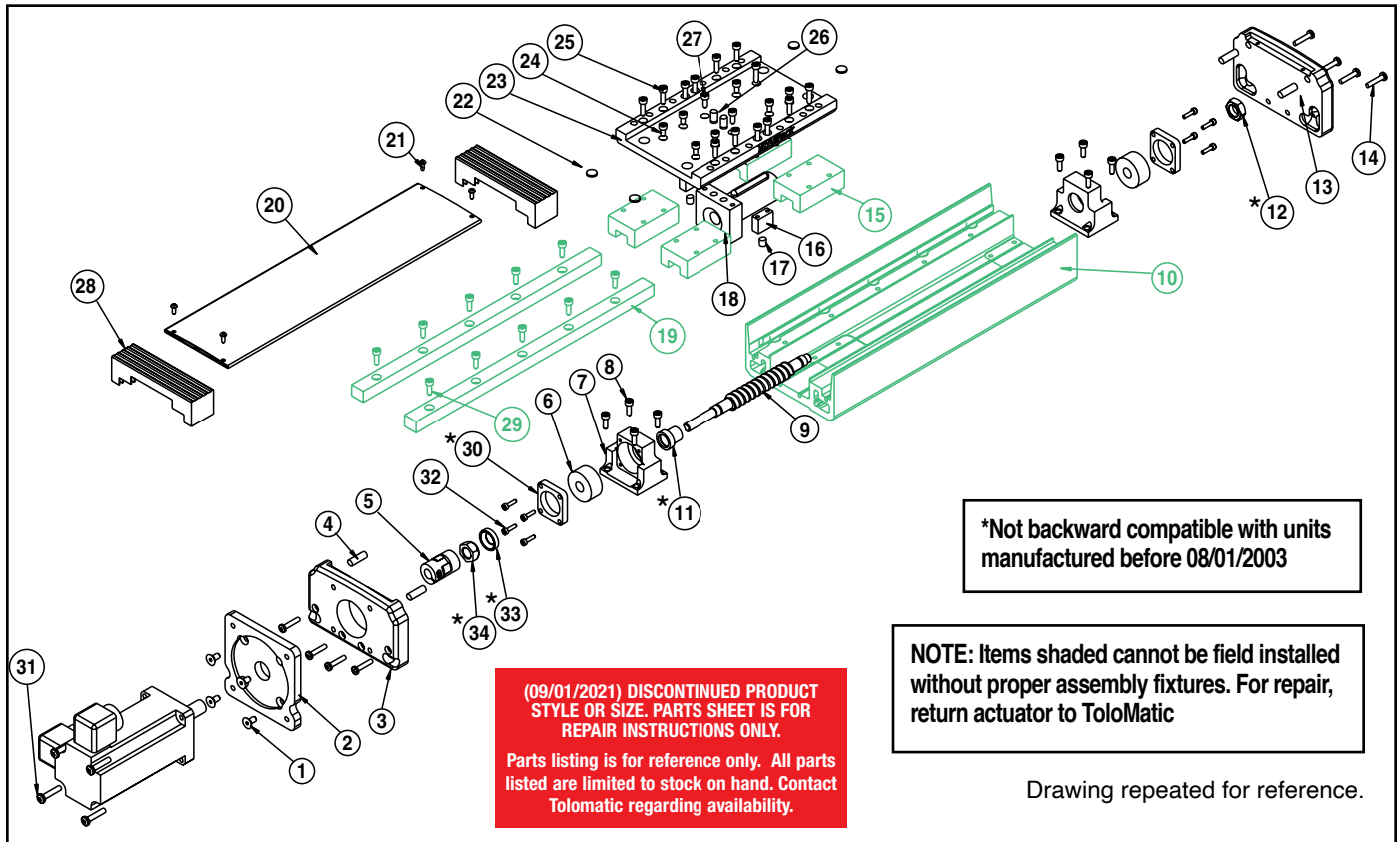

*Not backward compatible with units manufactured before 08/01/2003

NOTE: Items shaded cannot be field installed without proper assembly fixtures. For repair, return actuator to ToloMatic

(09/01/2021) DISCONTINUED PRODUCT STYLE OR SIZE. PARTS SHEET IS FOR REPAIR INSTRUCTIONS ONLY.
Parts listing is for reference only. All parts listed are limited to stock on hand. Contact ToloMatic regarding availability.

Drawing repeated for reference.

General Cylinder Disassembly Instructions

Begin with a clean work area. Be sure all replacement parts present and have no visual damage or defects. The following tools are recommended for proper disassembly and assembly.

- Metric Allen Wrench Set
- Torx bit set
- Metric Socket Set
- Metric Combination Wrench Set

1. **Carrier and Head Removal.** Remove Cover Screws (21) and remove the Cover (20). Remove all Cap Screws (24,25) that attach Carrier (23) to THK Blocks (15). Remove Cap Screws (27) that attach Carrier to Nut Connector (18). Lift carrier from THK Blocks and Nut Connector. Note that there are dowel pins locating the Carrier to Nut Connector. Remove Head Screws (14) to remove heads (3,13).
2. **Remove Lead Screw sub-assembly.** On the non-motor end of the actuator remove Nut (12) from Lead Screw (9). Remove the locknut on the motor end as well. Remove the Cap Screws (8) attaching Bearing Blocks (7) to the Base (10), and remove the non-motor end bearing block. The lead screw assembly can now be removed from the base. The motor end bearing is a press fit on the leadscrew journal. The use of a press may be required to get the bearing off. Remove the bearing clamps (30) from the bearing blocks in order to remove the bearings (6).

Ball nut style: Caution is required if removal of the nut is necessary. Contact the factory for available parts and procedures.

Plastic nut style: Plastic nuts are factory pinned into the Nut Connector and cannot be removed. If nuts are worn, a new Nut Connector Assy must be ordered.

General Cylinder Assembly Instructions

1. **Install Lead Screw assembly and Carrier.** Thoroughly clean the taper sleeve (11) and tapered portion of lead screw. With nut connector assembly and bearing block on the Lead Screw slide the tapered sleeve (29) onto the motor end of screw, then slide bearing up to leadscrew journal. The bearing must be pressed on to the leadscrew journal up to the tapered sleeve. Take caution to only apply press to the inner race of the bearing. Locate spherical washer (33) over exposed threads, apply Loctite 242 to the threads and locknut, and thread the locknut (34) onto the screw. Torque locknut to 200 in-lbs. Locate the bearing block over the bearing and install the bearing clamp, do not torque fasteners at this time. Slide the non-motor end bearing assembly over the end of the lead screw, and locate this assembly on the base. Secure both bearing blocks to the base. Torque Bearing Block fasteners (8) to 25 in-lbs. Verify that all bearing clamp fasteners are loose. Attach Carrier to the nut connector, locating on the dowel pins. Secure the fasteners attaching Carrier to the THK Bearing Blocks.
2. **Bearing Alignment.** Position the carrier near the motor end of the actuator. Torque the bearing clamp fasteners to 10 in-lbs. Re-position the carrier near the non-motor end of actuator, and torque the bearing clamp fasteners to 10 in-lbs. Apply Loctite 242 to the nut (12) and thread onto the non-motor end of lead screw. Torque this nut to 96 oz-in.
3. **Install Heads and Cover.** Attach Heads to the base with head screws (14). Install Cover (20) and attach with screws (21).

Reverse Parallel Screw Drive

(09/01/2021) DISCONTINUED PRODUCT STYLE OR SIZE. PARTS SHEET IS FOR REPAIR INSTRUCTIONS ONLY.

Parts listing is for reference only. All parts listed are limited to stock on hand. Contact Tolomatic regarding availability.

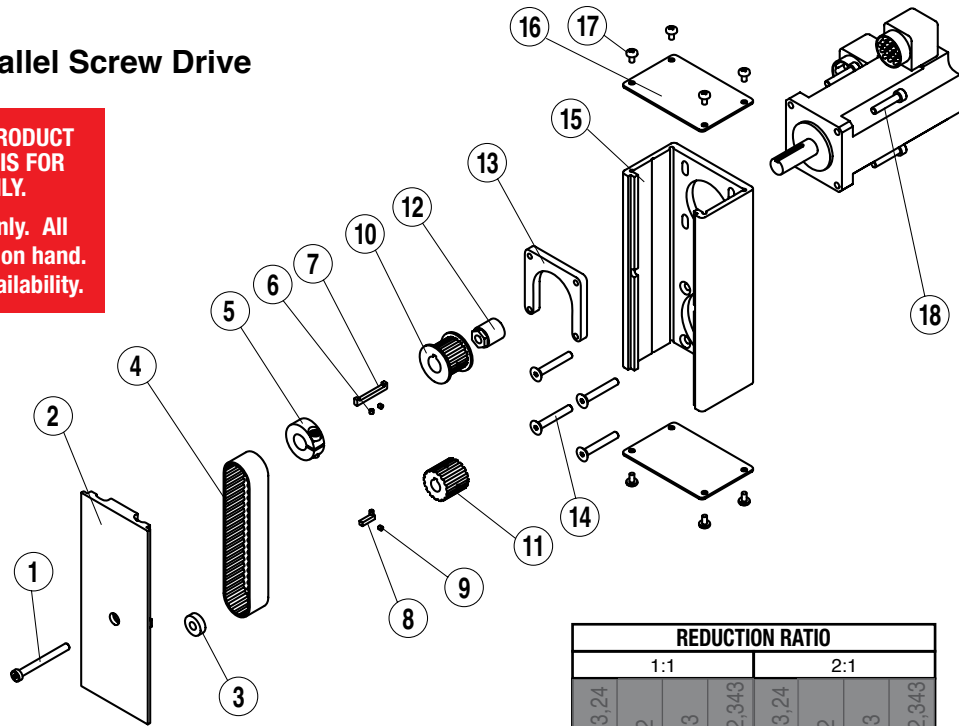

List of Parts

ITEM	Part No. or CONFIG. code	DESCRIPTION	REDUCTION RATIO							
			1:1				2:1			
			MRV21, 22, 23, 24	MRS231, 232	MRV31, 32, 33	MRS341, 342, 343	MRV21, 22, 23, 24	MRS231, 232	MRV31, 32, 33	MRS341, 342, 343
1	3420-1640	Screw	1	1			1	1		
	3420-1639	SHCS, M5 X 0.8, 55 MM LONG, SST			1	1			1	1
2	0601-1614	COVER	1	1			1	1		
	0602-1614	COVER, TKS25-34 FRAME			1	1			1	1
3	1812-1010	BEARING, BALL, RADIAL, Ø.250	1	1	1	1	1	1	1	1
4	2120-1028	TIMING BELT	1		1	1				
	2133-1025	TIMING BELT, 330-5M-19					1		1	1
	0602-2056	TIMING BELT, 295-5M-9		1						
	0602-2058	TIMING BELT, 330-5M-9						1		
5	2312-1005	CLAMP COLLAR, Ø.500				1				1
6	4415-1015	SET SCREW, M3 X 0.5 X 3 MM LONG	2	2	2	2	2	2	2	2
7	2132-1021	KEY, SPECIAL, .125 X .125	1	1	1	1	1	1	1	1
8	2100-1021	KEY, .125 X .125 X .75 LONG	1	1	1	1	1	1	1	1
	1004-7706	KEY, .125 X .125 X 1.00 LONG					1		1	1
	1817-1044	KEY, .125 X .125 X .50 LONG		1						
9	4415-1015	SET SCREW, M3 X 0.5 X 3 MM LONG	2	2	2	2	2	2	2	2
10	2132-1002	PULLEY	1		1	1	1	1	1	1
	0602-9850	PULLEY, 16 TEETH, 19 MM WIDTH				1				1
	0601-1062	PULLEY, 16 TEETH, 9 MM WIDTH		1				1		
11	0602-1664	PULLEY	1		1	1				
	0602-1665	PULLEY, 32 TEETH, 19 MM WIDTH					1		1	1
	0602-1664	PULLEY, 16 TEETH, 19 MM WIDTH		1						
	0602-1666	PULLEY, 32 TEETH, 9 MM WIDTH						1		
12	0510-1111	TRANTORQ		1				1		
13	0601-1053	PLATE, MOTOR	1	1			1	1		
	0602-1057	PLATE, MOTOR, 34 FRAME			1	1			1	1
14	0602-1064	SFHCS, M5 X 0.8 X 16 MM LONG, SST	4	4	4	4	4	4	4	4
15	0601-1604	HOUSING	1	1			1	1		
	0602-1604	HOUSING, TKS25-34 FRAME			1	1			1	1
16	0601-1602	END CAP	2	2			2	2		
	0602-1602	END CAP			2	2			2	2
17	0601-1625	SCREW, #6 X .25, SELF-TAPPING, SST	8	8	8	8	8	8	8	8
18	2212-1098	SHCS		4				4		
	2212-1099	SHCS, M5 X 0.8 X 25 MM LONG, SST	4		4	4	4		4	4

Reverse Parallel Disassembly Instructions

1. Remove End Cap's (16). Release tension on belt by breaking loose the motor fasteners (18).
2. Remove RP Cover (2).
3. Remove both drive pulley (10) and driven pulley (11) from their respective shafts. The belt (4) will come off with the pulley's.
4. Remove motor fasteners (18) from the RP case, to remove the motor from the RP case.
5. Remove the RP case (15) from the head by removing fasteners (14).

Reverse Parallel Assembly Instructions

*Apply Loctite #242 to all fasteners upon installation

1. Install RP case (15) to the head with cap screws (14). Do not fully tighten the fasteners at this time and verify that the RP case can move with respect to the head.
2. Temporarily install the cover (2) with bearing (3), onto the RP case positioning the bearing over the leadscrew shaft. Hold the cover in place while tightening 2 of the fasteners (14) that hold the RP case to the head.
3. Remove the cover (2) and finish tightening all fasteners attaching the RP case to the head.
4. Install the motor to the RP case with fasteners (18). Do not tighten the fasteners at this time.
5. Locate the belt (4) over the pulleys and slide the drive (10) and driven (11) pulleys over their respective shafts. Tighten each pulley to it's shaft with either trantorque or collar clamp. If trantorque, utilize torque wrench to apply 75 in-lbs.
6. Verify that there is clearance between the inside of the RP case and each pulley. Verify that the pulleys are aligned to each other.
7. Position the cover (2) in mating slot of the RP case and install the SHCS (1) to hold in place. Take care not to overtighten. If the cover is deflected it can interfere with the leadscrew.
8. Tension the belt by pulling the motor away from the drive shaft with appropriate force from literature # 3600-4212. Tighten the motor fasteners while this force is applied to the motor.

(09/01/2021) DISCONTINUED PRODUCT STYLE OR SIZE. PARTS SHEET IS FOR REPAIR INSTRUCTIONS ONLY.
Parts listing is for reference only. All parts listed are limited to stock on hand. Contact Tolomatic regarding availability.

Motor Frame	Tension Force
MRB23, MRS17/23	10 lbs
MRV23, MRS34	20 lbs
MRV34, MRB34	30 lbs

9. Install both end caps (16) with the screws (17) to finalize assembly.

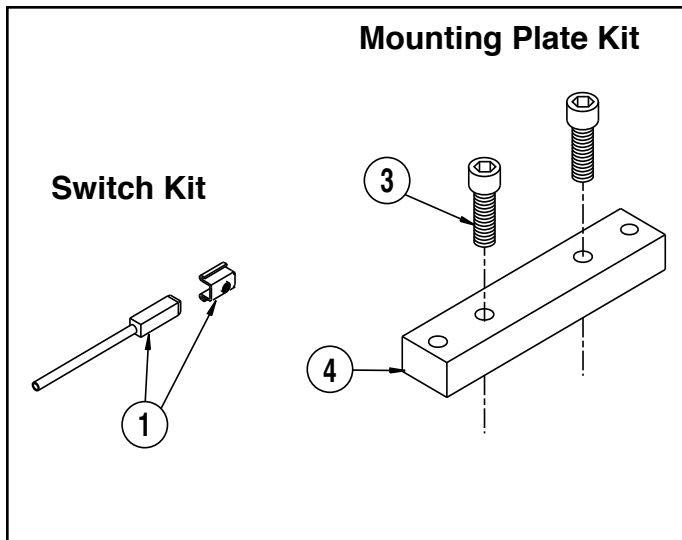

OPTIONAL ACCESSORY ASSEMBLY INSTRUCTIONS

1. **MOUNTING PLATES.** Mounting Plates should be secured at the required distances determined for the application to prevent tube deflection. Apply Loctite #242 to Screws and secure Mounting Plates to tube, aligning holes in tube with holes in Mounting Plates.

2. **SWITCHES**
NOTE: Form A Reed Switches should not be used in TTL logic circuits. A voltage drop caused by the L.E.D. indicator will result. For applications where TTL circuits are used, please contact the factory.

WARNING: An ohmmeter is recommended for testing Reed Switches. NEVER use an incandescent light bulb as a high current rush may damage the switch.

Reed switches are only recommended for signalling position, not directly powering solenoids. For shifting a solenoid, a relay or resistor is recommended between it and the Reed Switch. Switch ratings must not be exceeded at any time.

NOTE: For Hall Effect Switch Magnet, be sure the S pole of the magnet (indicated with black dot) is facing toward the switch (down).

NOTE: The side of the switch with the groove indicates the sensing surface. This must face toward the magnet.

TO ORDER RETROFIT KITS:
 SW (then the model number and base size, and code for type of switch needed).

EXAMPLE: SWTK25BT
 Where **SW** is the switch kit, **TK** is the model, **25** is the 1" size, and **BT** is a Form C Reed Switch with 5-meter lead.

List of Parts

Item	Part No. or CONFIG. code	Description	QTY.
SWITCH KIT			
1	SWTKS25RT	Switch, Reed, Form A, 5M Wire	AR
	SWTKS25BT	Switch, Reed, Form C, 5M Wire	AR
	SWTKS25TT	Switch, Source, Hall, 5M Wire	AR
	SWTKS25KT	Switch, Sinking, Hall, 5M Wire	AR
NOTE: Switch bracket with set screw is included			
MOUNTING PLATES			
3	2212-1101	SHCS M6 x 20	2
4	0602-1080	MOUNTING PLATE	1

*AR = as required

(09/01/2021) DISCONTINUED PRODUCT STYLE OR SIZE. PARTS SHEET IS FOR REPAIR INSTRUCTIONS ONLY.

Parts listing is for reference only. All parts listed are limited to stock on hand. Contact Tolomatic regarding availability.

SWITCH TYPE CODE	
BT	(Form C Reed Switch with 5-meter lead)
RT	(Form A Reed Switch with 5-meter lead)
KT	(Hall-effect Switch (Sinking) 5-meter lead)
TT	(Hall-effect Switch (Sourcing) 5-meter lead)

Universal Switch Wiring Diagrams and Label Color Coding

(09/01/2021) DISCONTINUED PRODUCT STYLE OR SIZE. PARTS SHEET IS FOR REPAIR INSTRUCTIONS ONLY.

Parts listing is for reference only. All parts listed are limited to stock on hand. Contact Tolomatic regarding availability.

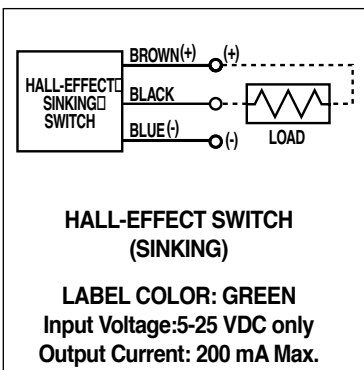
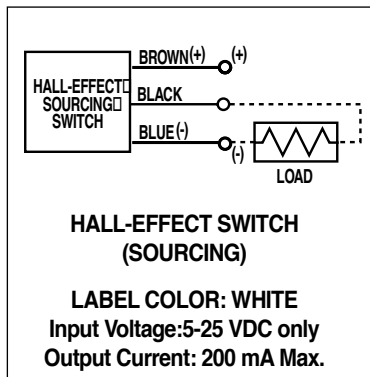
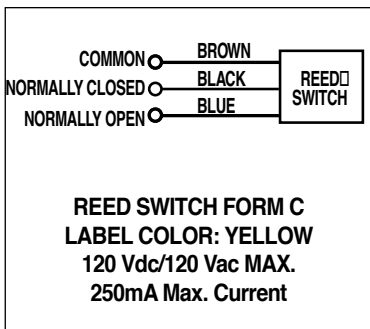
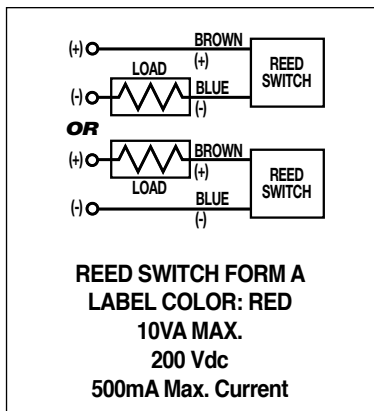

Christo-Lube® is a registered trademark of Lubrication Technology, Inc., www.lubricationtechnology.com
 Loctite® is a registered trademark of the Loctite Corporation, www.loctite.com
 Mobil grease® HP is a registered trademark of Mobil Oil Corporation, www.mobil.com



3800 County Road 116, Hamel, MN 55340
<http://www.Tolomatic.com> • Email: Help@Tolomatic.com
 Phone: (763) 478-8000 • Fax: (763) 478-8080 • Toll Free: 1-800-328-2174

COMPANY WITH QUALITY SYSTEM CERTIFIED BY DNV GL = ISO 9001 =

Information furnished is believed to be accurate and reliable. However, Tolomatic assumes no responsibility for its use or for any errors that may appear in this document. Tolomatic reserves the right to change the design or operation of the equipment described herein and any associated motion products without notice. Information in this document is subject to change without notice.