

Guided Screw Actuators, GSA

GSA32 2-inch (50mm) body size

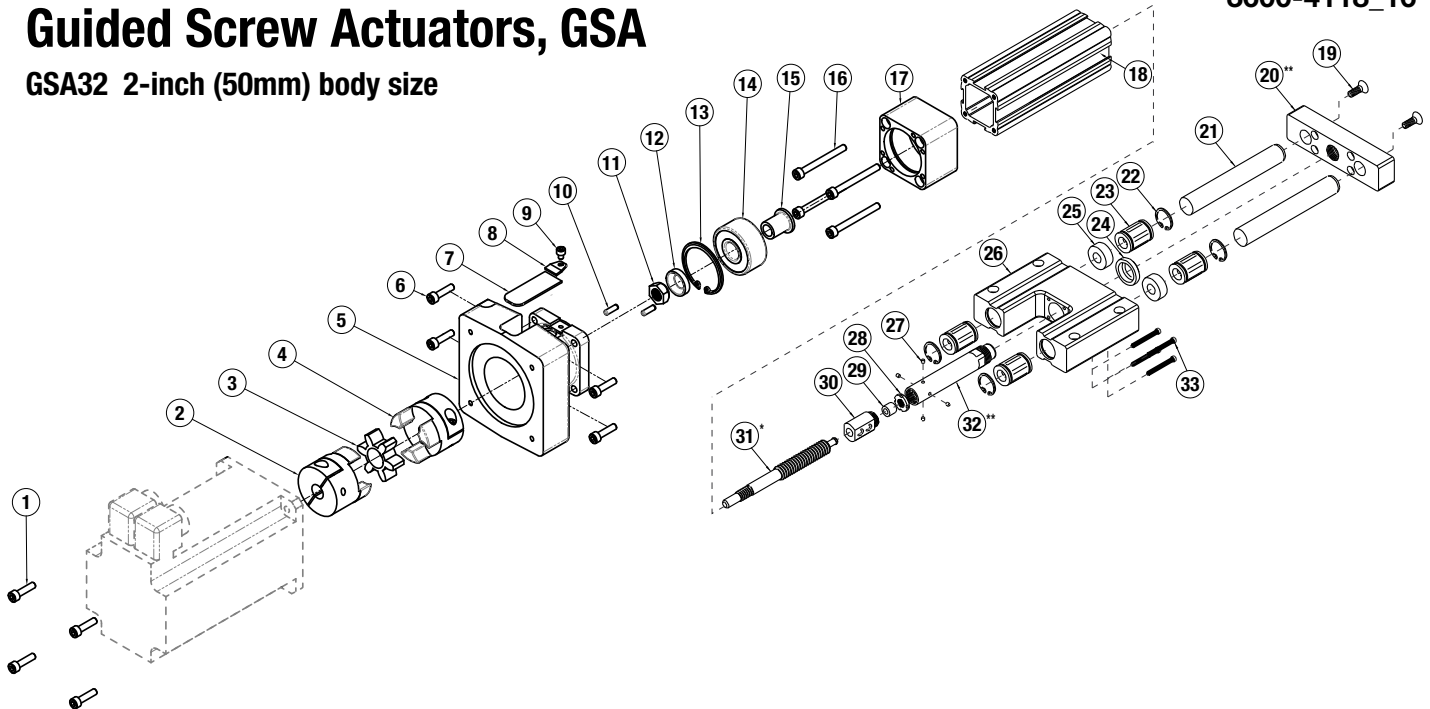

Inline Models (LMI)

ITEM	PART NO. OR CONFIG. CODE	DESCRIPTION	QTY
3 1.	CONFIGURED	MOTOR FASTENER	4
3 2.	CONFIGURED	MOTOR COUPLER HALF	1
3 3.	CONFIGURED	SPIDER	1
3 4.	CONFIGURED	ACTUATOR COUPLER HALF	1
3 5.	CONFIGURED	MOTOR SPACER	1
3 6.	CONFIGURED	MOTOR SPACER FASTENER	4
7.	3410-1120	MOTOR SPACER COVER	1
8.	1906-1022	COVER CLAMP	1
9.	1124-1159	COVER FASTENER	1
10.	1820-1003	DOWEL PIN	2
11.	1132-1013	SPHERICAL LOCK NUT	1
12.	1132-1014	SPHERICAL WASHER	1
13.	2120-1021	RETAINING RING	1
14.	2100-1012	BEARING	1
1 15.	1132-1044	LEADSCREW SLEEVE	1
16.	2232-1011	BEARING PLATE FASTENER	4
17.	1132-1037	BEARING PLATE (US CONV.)	1
	2132-1037	BEARING PLATE (METRIC)	1
4 18.	2232-1004	CYLINDER BODY	1
19.	2232-1010	GUIDE ROD FASTENER (US CONV.)	2
	3232-1010	GUIDE ROD FASTENER (METRIC)	2
20.	2232-1060	TOOLING PLATE STANDARD ROD (US CONV.)	1
	2232-1061	TOOLING PLATE OVERSIZE ROD (US CONV.)	1
	3232-1060	TOOLING PLATE STANDARD ROD (METRIC)	1
	3232-1061	TOOLING PLATE OVERSIZE ROD (METRIC)	1

ITEM	PART NO. OR CONFIG. CODE	DESCRIPTION	QTY
3 21.	CONFIGURED	GUIDE ROD	1
22.	2232-1007	RETAINING RING	1
23.	2332-1011	LINEAR BEARING	1
	2232-1009	COMPOSITE BEARING STANDARD	1
	2232-1012	COMPOSITE BEARING OVERSIZE	1
24.	2133-1030	WIPER RING	1
25.	2232-1005	WICK STANDARD ROD	2
	2232-1006	WICK OVERSIZE ROD	2
26.	2232-1001	HOUSING (US CONV.)	1
	3232-1001	HOUSING (METRIC)	1
27.	2224-1016	MAGNET ROD	4
28.	2232-1024	LEADSCREW FRONT BUSHING	1
29.	0745-1008	LOCK NUT	1
30.	0520-1042	BN02 BALLNUT	1
	0920-1122	BN05 BALLNUT	1
	2733-1445	BNM20 BALLNUT	1
	2132-1026	BZ10 BRONZE NUT	1
1,3,4 31.	RLSGSA32_	LEADSCREW	1
3 32.	TRAGSA32_	THRUST ROD	AR
33.	2232-1011	GUIDE HOUSING FASTENER	4

¹Not backward compatible with units manufactured before 01/01/2003

²Not backward compatible with units manufactured before 03/01/2003

³Part number varies depending on YMH (Your Motor Here). Contact help@tolomatic.com for replacement part number.

⁴ Replacement ordering method: **RLSGSA32** **SK** **YM**

EXAMPLE: RLSGSA32 SN01 SK21-25 YM

Replacement Lead Screw Model & Size Nut Style & Size Stroke Length Motor Code

Solid Nut, Ball Nut RP

(Reverse Parallel motor mount)

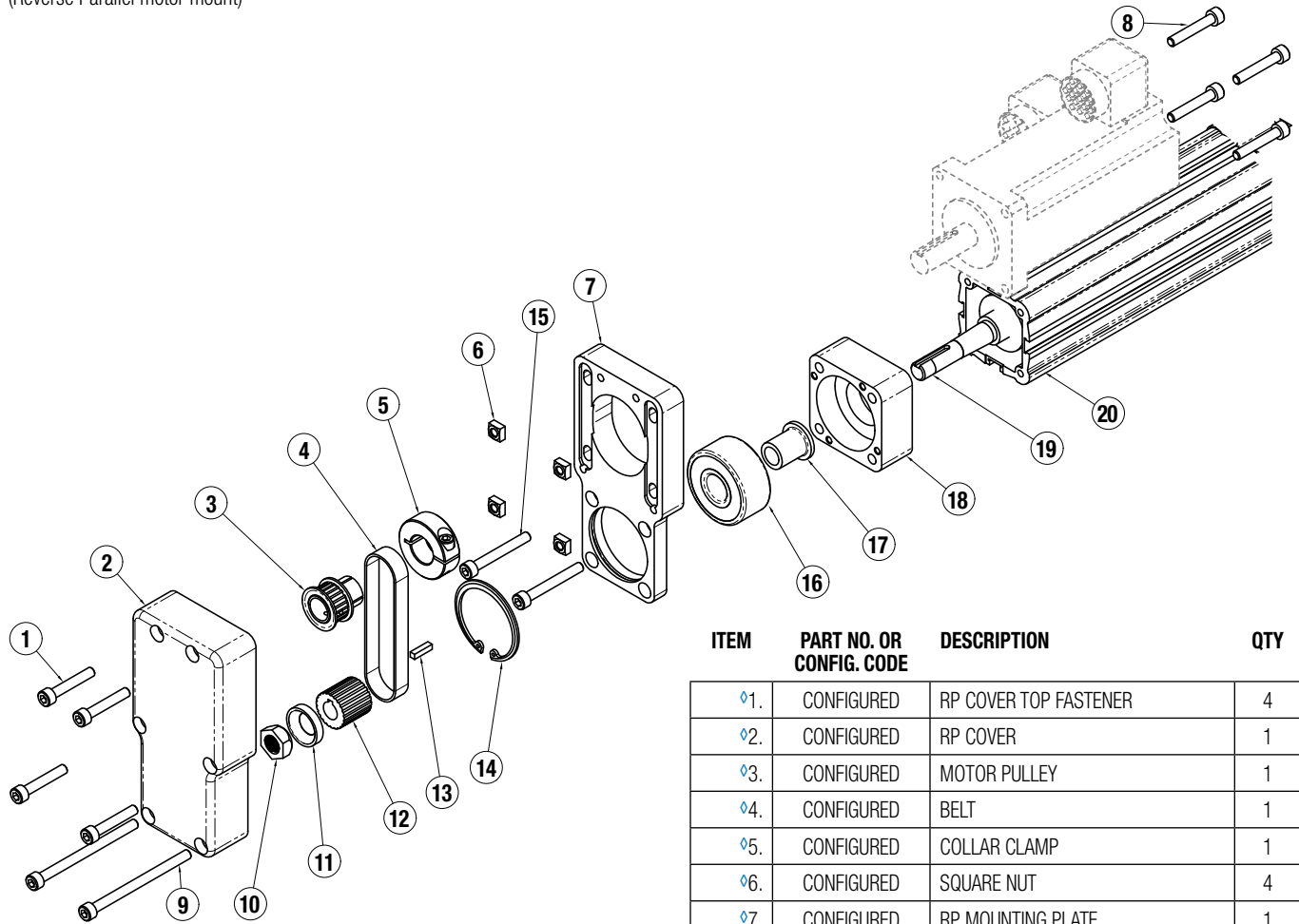

ITEM	PART NO. OR CONFIG. CODE	DESCRIPTION	QTY
♦1.	CONFIGURED	RP COVER TOP FASTENER	4
♦2.	CONFIGURED	RP COVER	1
♦3.	CONFIGURED	MOTOR PULLEY	1
♦4.	CONFIGURED	BELT	1
♦5.	CONFIGURED	COLLAR CLAMP	1
♦6.	CONFIGURED	SQUARE NUT	4
♦7.	CONFIGURED	RP MOUNTING PLATE	1
♦8.	CONFIGURED	MOTOR FASTENER	4
♦9.	CONFIGURED	RP COVER BOTTOM FASTENER	2
*10.	1124-1082	SPHERICAL LOCK NUT	1
*11.	1124-1092	SPHERICAL WASHER	1
♦12.	CONFIGURED	ACTUATOR PULLEY	1
♦13.	CONFIGURED	KEY	1
14.	2100-1010	RETAINING RING	1
15.	0601-1144	RP MOUNTING PLATE FASTENER	2
16.	3420-1222	BEARING	1
17.	1124-1044	LEADSCREW SLEEVE	1
18.	1124-1037	BEARING PLATE (US CONV.)	1
	2124-1037	BEARING PLATE (METRIC)	1
† 19.	RLSGSA32 __	LEADSCREW	1
† 20.	RTBGSA32 __	CYLINDER BODY	1

*These parts are not compatible with actuators manufactured before January 2003.

♦ Part number varies depending on YMH (Your Motor Here).
Contact help@tolomatic.com for replacement part number.

† Replacement ordering method: **RLSGSA32** **SK** **YM**

EXAMPLE: **RLSGSA32SN01SK21-25YM**

Replacement Lead Screw Model & Size Nut Style & Size Stroke Length Motor Code

Drawing repeated for reference

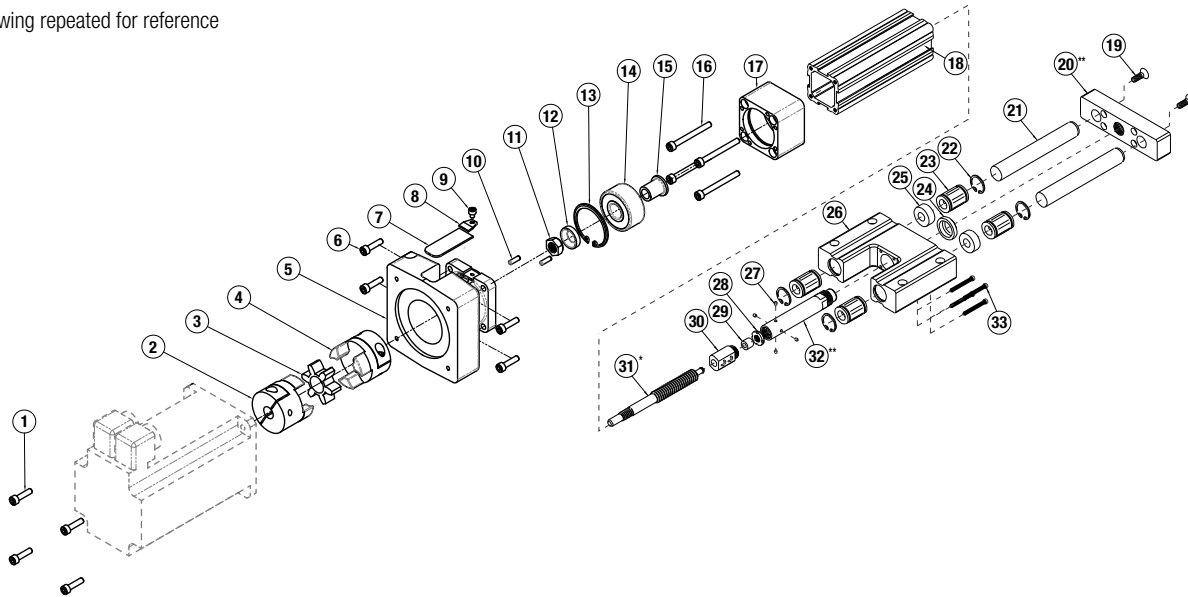

General Cylinder Disassembly Instructions

Begin with a clean work area. Be sure all replacement parts are present and have no visual damage or defects. The following tools are recommended for proper disassembly and assembly.

- Allen wrench set (metric)
- Socket wrench & socket set
- Retaining ring pliers (internal & external)

- 1. LMI Unit, Remove motor and motor spacer:** Loosen the coupler screw closest to the actuator. Remove four Motor Spacer Fastener (6) that hold the motor spacer onto actuator body. Remove the motor spacer/motor assembly.

RP, Solid Nut/Ball Nut: (Note: Reference parts list from page 2 whenever instructions refer to RP with Solid Nut/Ball Nut.) Disassemble the RP [Reverse Parallel] assembly in the following order:

- 1) Loosen the Motor Mount Fasteners (8) to remove belt tension.
- 2) Remove RP Cover (2) by removing the six Socket Head Cap Screws (1,9).
- 3) Remove Belt (4).
- 4) Remove the motor by removing the Motor Mount Fasteners (8) and the Square Nuts (6).
- 5) Remove the RP Plate (7) by removing two Socket Head Cap Screws (15). Note: the Retaining Ring (14) is part of the RP Plate. A portion of the Bearing (16) will be protruding from the Bearing Plate (18). The Bearing Plate (18) is no longer secured to the actuator body.

- 2. Remove the Tooling Plate Assembly:** Using a wrench, unscrew the Thrust Rod (32) from the Tooling Plate (20). Slide the Tooling Plate (20) (Guide Rods (21) still attached) out from the Housing (26).
- 3. Remove Bearing Plate/Leadscrew Assembly:** Remove the four Motor Spacer Fastener (6) that hold the Bearing Plate (17) to the actuator body. Slide the Bearing Plate (17), Leadscrew (31), Thrust Rod (32) assembly out of the Cylinder Body (18). Note: the Thrust Rod (32) may need to be "unscrewed" from the Wiper Ring (24) in the Housing (26) in order to do this.

- 4. Remove the Thrust Rod/Nut Assembly:** Remove the Lock Nut (29) and Leadscrew Front Bushing (28) from the non-motor end of the Leadscrew (31).

Plastic nut style: The Leadscrew (31) can be threaded out of the Nut (32) at this point.

Ball nut style: Caution is required if removal of the Nut (32) or Leadscrew (31) is required. Contact the factory for available parts and procedures. Note: if Ballnut (32) is removed from screw, ball bearings will fall out!

- 5. Remove Bearing Plate from Leadscrew:** Hold the Leadscrew (31) in a smooth jaw vice and remove the Spherical Lock Nut (11). Support the Bearing Plate (17), and press the Leadscrew (31) out of the Bearing (14)/Leadscrew Sleeve (15). The Leadscrew Sleeve (15) is a press fit in the bearing and should not be re-used. Remove the Retaining Ring (22) from Bearing Plate (17) and press the bearing out of the Bearing Plate (17).

- 6. Remove the Housing from the Cylinder Body:** Remove Guide Housing Fastener (33) from the Housing (26) to detach it from the actuator body. The Wiper Ring (24) can be removed from the Housing (26) at this time.

- 7. Remove the Shafts from Tooling Plate:** Remove Guide Rod Fastener (19) from Tooling Plate (20). Use a press and a tool that will fit inside the thread inside the Guide Rod (21) and press out the Guide Rods (21).

- 8. Guide Bearing & Wick removal (linear bearings only):** Remove Retaining Rings (22) from the Housing (26). Slide out Linear Bearings (23). Using a screwdriver or similar tool, remove the lubrication Wicks (25). Note: the composite style of bearings are pressed in the Housing (26), they can't be removed.

General Cylinder Assembly Instructions:

- 1. Install Wick and Guide Bearings (linear bearings only):** Apply a light amount of oil to each Wick (25) so that they are damp. Install the wick into each groove of the Housing (26). Install four Retaining Rings (22) into the Housing (26). Rotate them such that the ball races are not aligned with each other on opposite ends of the Housing (26). Install Actuator Coupler Half (4) to hold them in place. The flat side of the ring goes against the bearing. Install Motor Spacer Fasteners (6) into groove in Housing (26). Make sure tapered edge of ring faces "out" of Housing (26).

- 2. Install bearing into Bearing Plate:** Press Leadscrew Sleeve (15) into Bearing (4). Apply a coating of Loctite 641 to the ID of the Bearing Plate (17)/RP case and the OD of the bearing. Locate the Bearing Plate (17)/RP Housing (26) over the bearing and install the Retaining Ring (22).

- 3. LMI, Install Bearing onto Leadscrew:** Clean ID of Leadscrew Sleeve (15) and OD of taper on Leadscrew (31). Position Bearing (14)/Leadscrew Sleeve (15) over the Leadscrew (31). Install the Spherical Washer (12) over Leadscrew (31). Apply Loctite 242 to threads of Leadscrew (31) and threads of Spherical Locknut (11). Thread on the Locknut and torque to 200 in-lbs [22.6 N-m]. Hold leadscrew in machinist vice as needed.

RP, Solid Nut/Ball Nut: (Reference parts list on page 2.) Install Leadscrew (31) into the Leadscrew Leadscrew Sleeve (15) and apply Loctite 242 to the threads of the Leadscrew (31). Place Key (13) onto Leadscrew (31) and

install the Pulley (12), Washer (11), and Lock Nut (10) over Leadscrew (31). Torque Lock Nut (10) to 200 in-lbs. Hold Leadscrew (31) in machinist vice as necessary.

4. Install guide Guide Rods into Tooling Plate: Press Guide Rod (21) into hole in Tooling Plate (20). The end of the Guide Rod (21) with the threads in it goes into the Tooling Plate (20). Note: It is very important to press the Guide Rod (21) in straight! Use some sort of guide if possible. Repeat this for the other Guide Rod (21). Apply blue Loctite 242 to the threads of each Guide Rod Fastener (18) and thread into Guide Rods (21). Hand tighten.

5. Install nut, thrust rod onto Leadscrew:
Plastic nut style: Temporarily thread the Nut (30) into Thrust Rod (32) and drill w/ 1/8th bit. Remove Nut (30) from rod and thread the Nut (30) onto the Leadscrew (31). Install the Leadscrew Front Bushing (28) and Lock Nut (29) on end of Leadscrew (31). Apply a coating of loctite 271 to the Nut (30) and thread into the Thrust Rod (32) and tighten. Install pins thru Thrust Rod (32) and into the Nut (30).
Ball nut style: Ballnut (30) is threaded into Thrust Rod (32) w/ Loctite 271.

6. Lubricate the Leadscrew:
Plastic Nut: Apply a liberal film of Christo-Lube® 405 grease along the Leadscrew (31). Apply a thin film of the same grease along the ID of Thrust Rod (32).
Ballnut: Apply a liberal film of Mobilgrease® HP (Mobil blue) along the Leadscrew (31). Apply a thin film of the same grease along the ID of Thrust Rod (32).

7. Main actuator assembly: Locate the Cylinder Body (18) over the Thrust Rod (32)/Leadscrew assembly. Position the Housing (26) (9) over the Thrust Rod (32). Insert the Tooling Plate (20)/Guide Rods (21) into the Housing (26). Apply loctite 242 to the thread of the Thrust Rod (32). Thread into the Tooling Plate (20) hand tight. With a wrench, tighten the Thrust Rod (32) turn. Then continue tightening until the nearest set of flats on the Thrust Rod (32) align w/ the edges of the Tooling Plate (20). This is necessary in order to align the

magnets w/ the switch slots in the Cylinder Body (18). Install Guide Housing Fastener (33) thru Housing (26) and tighten. Install the Bearing Plate Fasteners (16), and tighten.

8. LMI Unit, attach Motor: Attach Coupler (2,3,4) to the actuator Guide Rod (21). Attach Motor Spacer (5) to the actuator. Attach motor to the spacer and tighten down coupler fastener to motor Guide Rod (21).

RSA24ST REVERSE PARALLEL MOTOR ASSEMBLY INSTRUCTIONS

(Note: Reference parts list from page 2 whenever instructions refer to RP with Solid Nut/Ball Nut.)

1. Align motor with slots RP Mounting Plate (7). Install four Motor Fasteners (8) through motor and RP Mounting Plate (7) then into the four Square Nuts (6). The Square Nuts (6) must seat into the pockets of the RP Mounting Plate (7). Tighten enough so motor is not drooping but able to move vertically.
2. Align the Collar Clamp (5) with the Motor Pulley (3) and install the Motor Pulley (3) onto the motor Guide Rod (21) by tightening the Collar Clamp (5) fastener. Align motor pulley with the Actuator Pulley (12).
3. Slide Belt (4) over Motor Pulley (3) and Actuator Pulley (12).
4. Attach RP Cover (2) to RP Mounting plate (7):
Solid Nut/Ball Nut: Install RP Cover (2) using two RP Cover Bottom Fasteners (9) through the RP cover, RP mounting plate, and Bearing Plate (17) and into Cylinder Body (20). Install the remaining four RP Cover Top Fasteners (1) into the RP mounting plate.
5. Tension the belt following the procedures for the correct model number found listed in [RP Belt Tensioning 3600-4212](#).

Christo-Lube® is a registered trademark of Lubrication Technology, Inc., www.lubricationtechnology.com
 Loctite® is a registered trademark of the Loctite Corporation, www.loctite.com
 Mobil grease® HP is a registered trademark of Mobil Oil Corporation, www.mobil.com

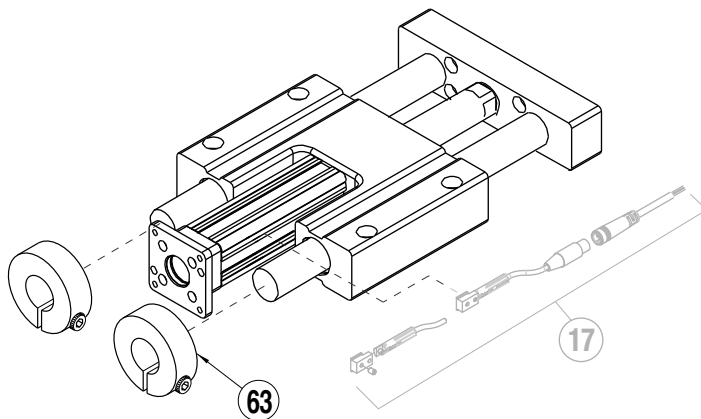

STOP COLLARS			
ITEM	PART #	DESCRIPTION	QTY
63.	2332-1005	STANDARD STOP COLLAR	2
	2332-1056	STAINLESS-STEEL STOP COLLAR	2
	2348-1005	OVERSIZE STOP COLLAR	2
	2348-1056	OVERSIZE STAINLESS-STEEL STOP COLLAR	2

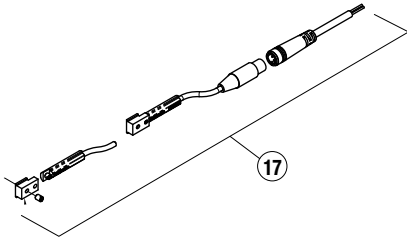

To order switch kits use configuration code for switch preceded by SW and actuator code.

EXAMPLE: **SWRSAL12KK3**

SW	R	S	A	1	2	K	K	3
KIT	ACTUATOR	SIZE	SWITCH CODE	QUANTITY				

The example is for 3 Solid State NPN, Normally Open Switches with Quick-disconnect couplers. Each switch is complete with Bracket, Set Screw, Switch and mating QD cable. Note that the bracket/switch size is common and may be used on any size RSA.

ITEM	ORDER CODE	LEAD	SENSOR TYPE	SWITCHING LOGIC	POWER LED	SIGNAL LED	OPERATING VOLTAGE	**POWER RATING (WATTS)	SWITCHING CURRENT (MA MAX.)	CURRENT CONSUMPTION	VOLTAGE DROP	LEAKAGE CURRENT	TEMP. RANGE	SHOCK / VIBRATION
17.	RY	5M	REED	SPST NORMALLY OPEN	—	RED	5 - 240 AC/DC	**10.0	100MA	—	3.0 V MAX.	—	14 TO 158°F [-10 TO 70°C]	50 G / 9 G
	RK	QD*												
	NY	5M		SPST NORMALLY CLOSED	—	YELLOW	5 - 110 AC/DC							
	NK	QD*												
	TY	5M	SOLID STATE	PNP (SOURCING) NORMALLY OPEN	GREEN	YELLOW	10 - 30 VDC	**3.0	100MA	20 MA @ 24V	2.0 V MAX.	0.05 MA MAX.		
	TK	QD*												
	KY	5M		NPN (SINKING) NORMALLY OPEN	GREEN	RED								
	KK	QD*												
	PY	5M		PNP (SOURCING) NORMALLY CLOSED	GREEN	YELLOW								
	PK	QD*												
	HY	5M		NPN (SINKING) NORMALLY CLOSED	GREEN	RED								
	HK	QD*												

SWITCH BRACKET, SET SCREW & MATING QD CABLE IS INCLUDED

*QD = Quick-disconnect

Enclosure classification IEC 529 IP67 (NEMA 6)

CABLES: Robotic grade, oil resistant polyurethane jacket, PVC insulation

**WARNING: Do not exceed power rating (Watt = Voltage x Amperage). Permanent damage to sensor will occur.

SWITCH INSTALLATION



Place switch bracket into one of the four slots that run the length of the extruded Cylinder Body. Note that there is a cutout on the actuator head (RSA) or tube (GSA) to allow insertion of the bracket. Insert the switch with the word "Tolomatic" facing up and slide it under the bracket. Position the bracket with the switch to the exact location desired, then lock them securely into place by tightening both set screws on the bracket.

SWITCH DIMENSIONS

- direct connect

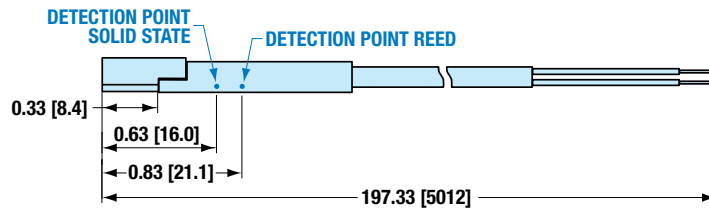

- QD (Quick-disconnect) switch

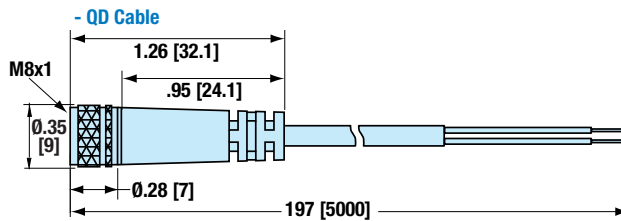
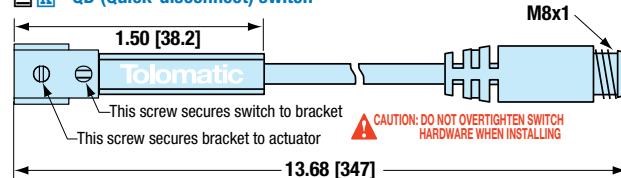

Dimensions in inches [brackets indicate dimensions in millimeters]

SWITCH WIRING DIAGRAMS AND LABEL COLOR CODING (CE and RoHS Compliant)

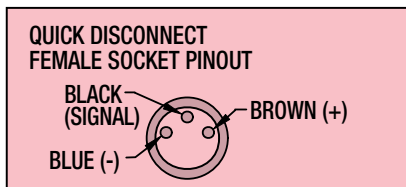
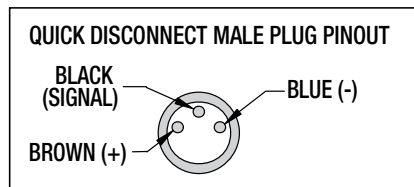
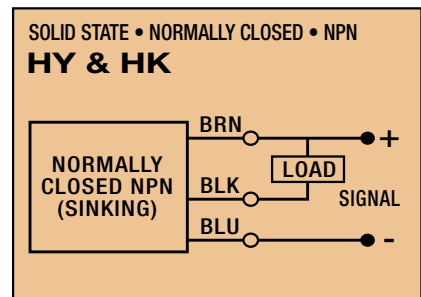
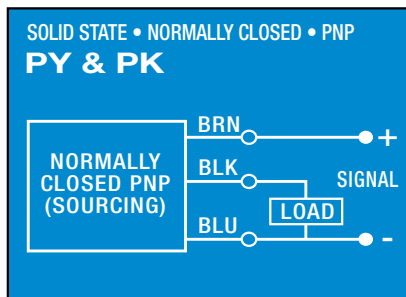
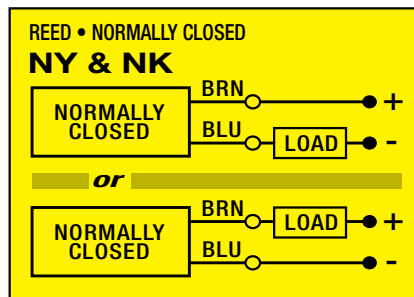
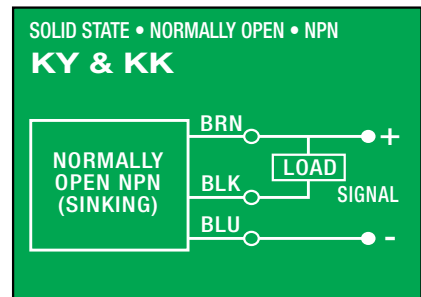
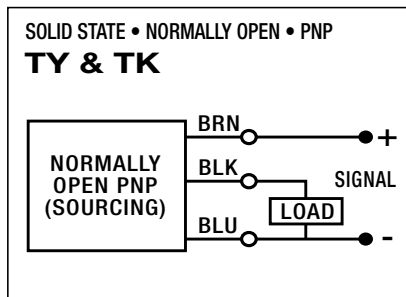
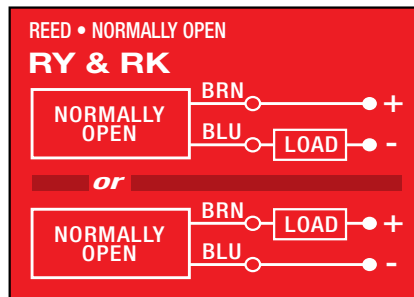

- Switches:
- Include retained mounting hardware
 - In slot, sit below extrusion profile
 - Same for all sizes



3800 County Road 116, Hamel, MN 55340 USA
 http://www.Tolomatic.com • Email: Help@Tolomatic.com
 Phone: (763) 478-8000 • Fax: (763) 478-8080 • Toll Free: 1-800-328-2174

COMPANY WITH
 QUALITY SYSTEM
 CERTIFIED BY DNV

All brand and product names are trademarks or registered trademarks of their respective owners. Information in this document is believed accurate at time of printing. However, Tolomatic assumes no responsibility for its use or for any errors that may appear in this document. Tolomatic reserves the right to change the design or operation of the equipment described herein and any associated motion products without notice. Information in this document is subject to change without notice.