

BC3 Series™ Band Cylinder® Wedge Style

BC315/BC3M(M)15 1.5"/40 mm BORE

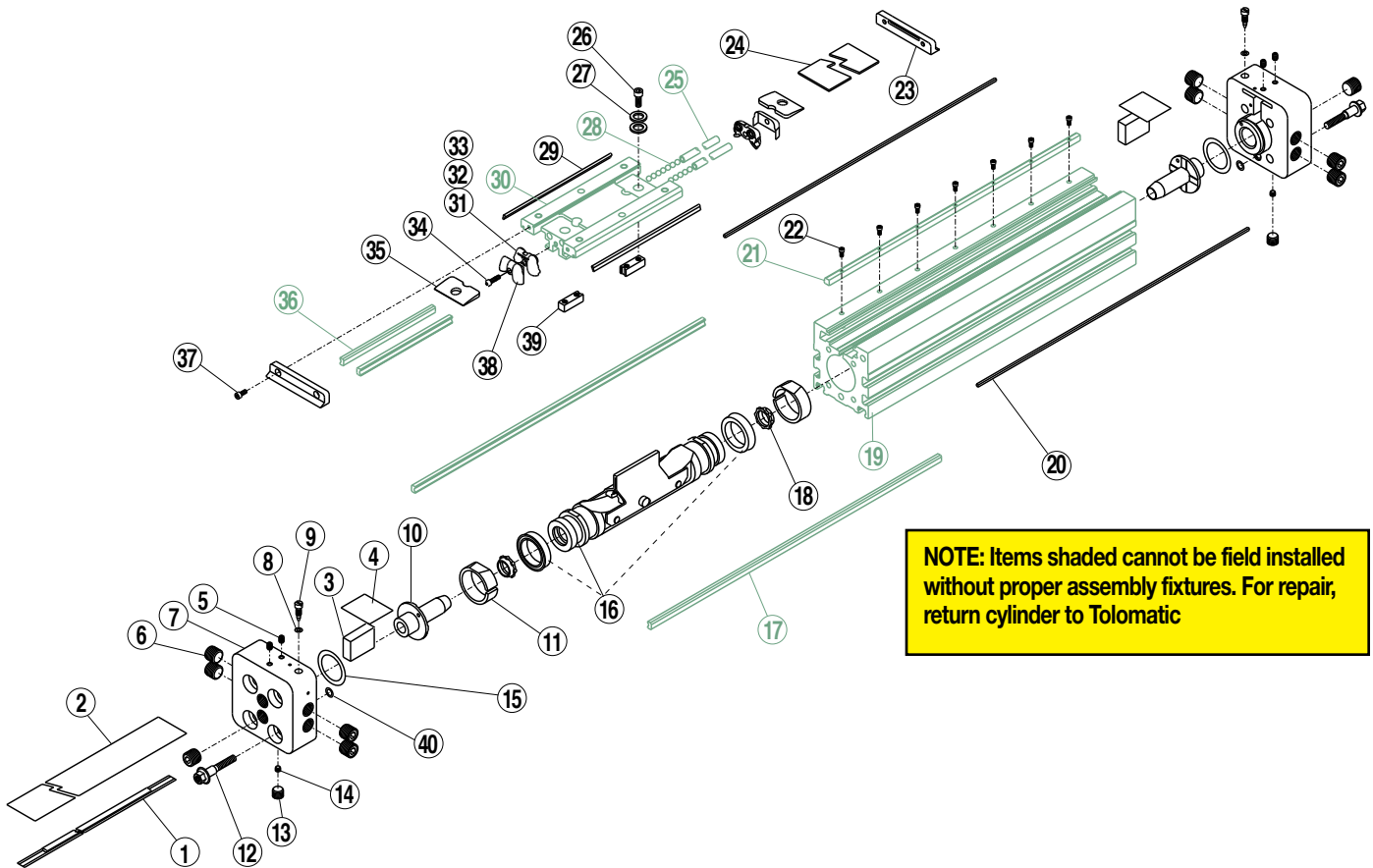

NOTE: Items shaded cannot be field installed without proper assembly fixtures. For repair, return cylinder to Tolomatic

ITEM	BC315 PART NO. or CONFIG. CODE	BC3M(M)15 PART NO. or CONFIG. CODE	DESCRIPTION	QTY.
1 ^{3,5}	NSBBC315	NSBBC3M15 NSBBC3MM15	Replacement Sealing Band (0915-9016)	1
2 ^{3,5}	NDBBC315	NDBBC3M15 NDBBC3MM15	Replacement Dust Band (3415-1028)	1
3	3415-1030	3415-1030	Clamp	2
4	3415-1045	3415-1045	Clamp Pad	2
5	3415-1455	4915-1044	Set Screw	4
6 ¹	1004-1073	4915-1002	Pipe Fitting	10
7 ¹	3415-1007	—	Standard Head	2
	—	4415-1007	Metric Taper Head	2
	—	5415-1007	Metric Parallel Head	2
8 ^{1,3,4}	0910-1178	0910-1178	Buna-N O-ring	2
9 ¹	0915-1177	0915-1177	Cushion Needle	2

ITEM	BC315 PART NO. or CONFIG. CODE	BC3M(M)15 PART NO. or CONFIG. CODE	DESCRIPTION	QTY.
10	0915-1224	0915-1224	Cushion Spear	2
11 ^{3,4}	0915-1110	0915-1110	Wear Ring	2
12 ²	0512-1011	4512-1011	Head Bolt	8
13	1014-1065	5510-1002	Pipe Plug	2
14 ¹	3410-1005	4415-1009	Pipe Plug	2
15 ^{3,4}	0915-1178	0915-1178	Buna-N O-ring	2
16	3415-9000	3415-9000	Piston/Bracket Assembly with magnet	1
17	3415-1023	3415-1023	Rail way	2
18 ^{3,4}	0915-1184	0915-1184	Cushion Seal	2
19	3415-1081	3415-1081	Machined Tube	1
20 ⁵	NMBBC315	NMBBC3M15 NMBBC3MM15	Replacement Magnet Band (3415-1022)	2

1 Items available as Standard Head Assembly #3415-9001, Metric Taper Head Assembly #4415-9001 and Metric Parallel Head Assembly #5415-9001.

2 When replacing the head bolts in actuators manufactured prior to July 1, 2006, the hole for the head bolt will need to be drilled 0.4" (10mm) deeper to accommodate the longer screw length.

COMMON REPLACEMENT PARTS:

3 **Repair Kit:** Parts contained in Repair Kit RKBC315SK_ _ _

4 **Seal Kit:** Parts contained in Seal Kit #3415-9019

5 After configuration code add: **SK_ _ _** (note: the letters SK indicate stroke, follow these letters with the stroke length in decimal inches.)

If the actuator has the dual carrier option add the code **DW_ _ _** (note: follow the letters DW with the distance between the carriers in decimal inches.)

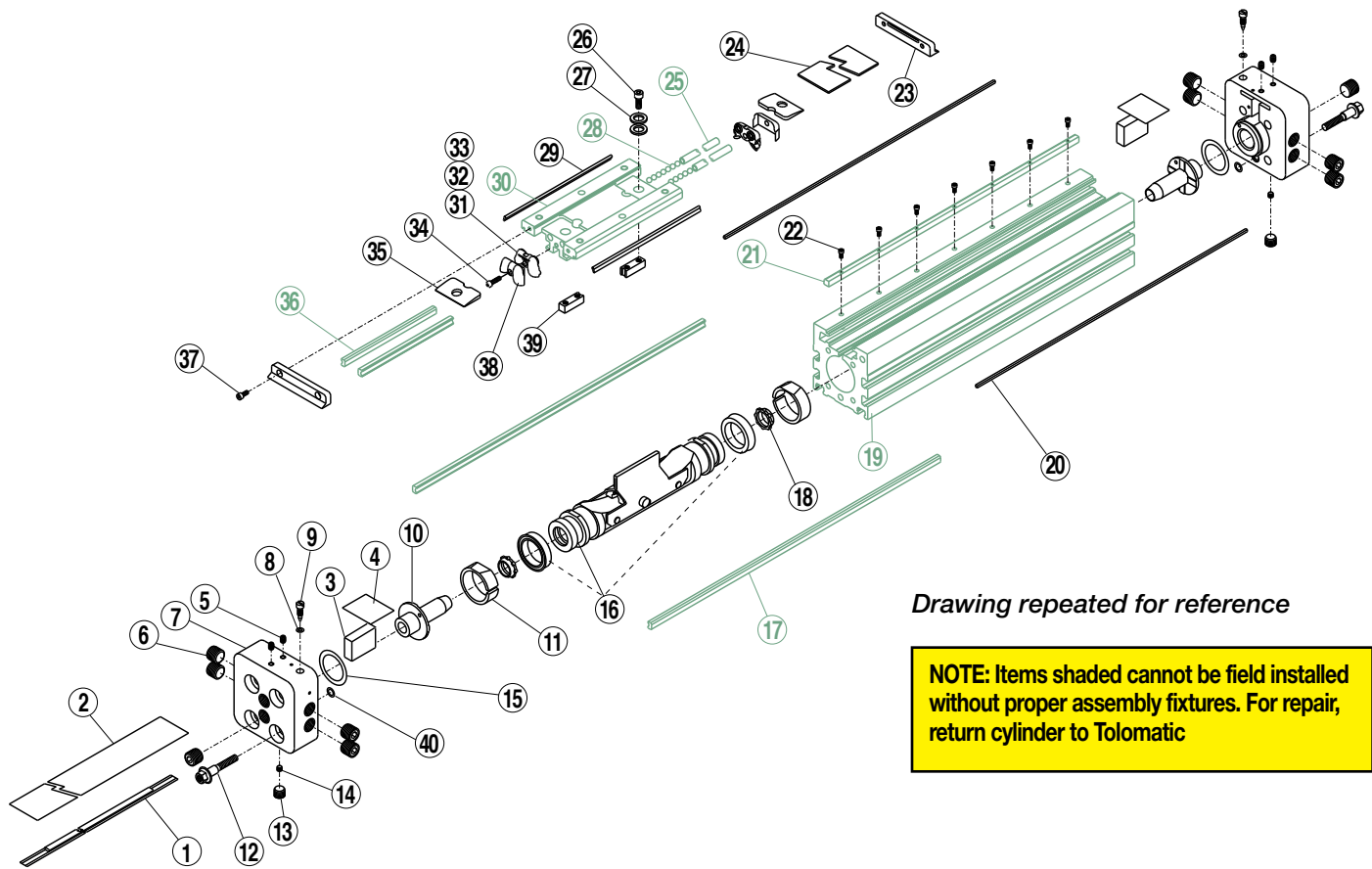

Drawing repeated for reference

NOTE: Items shaded cannot be field installed without proper assembly fixtures. For repair, return cylinder to Tolomatic

ITEM	BC315 PART NO. or CONFIG. CODE	BC3M(M)15 PART NO. or CONFIG. CODE	DESCRIPTION	QTY.
21	3415-1140	3415-1140	Machined Wedge	1
22	0605-1048	0605-1048	SHCS	A/R
23 ^{3,4}	3415-2024	3415-2024	End Cap	2
24	3415-2022	3415-2022	Carrier Cover	1
25	3415-1019	3415-1019	Ball Return Tube	2
26	0707-1010	4415-1016	Socket Head Cap Screw	4
27	3410-1048	3410-1048	Washer	8
28	3415-1009	3415-1009	Ball	114
29 ^{3,4}	3415-1025	3415-1025	Wiper	2
30	3415-2021	4415-1235	Machined Carrier	1
31	3415-1014	3415-1014	Ball Return	2
32	3415-1015	3415-1015	Right Ball Race	2

ITEM	BC315 PART NO. or CONFIG. CODE	BC3M(M)15 PART NO. or CONFIG. CODE	DESCRIPTION	QTY.
33	3415-1032	3415-1032	Left Ball Race	2
34	2307-1021	3210-1025	Socket Head Cap Screw	2
35	3415-1047	3415-1047	Upper Band Ramp	2
36	3415-1024	3415-1024	Carrier Way	2
37	0910-1040	4415-1001	Socket Head Cap Screw	4
38	3415-1109	3415-1109	PLT, Ball Return	2
39	3415-1010	4415-1010	Piston Block	2
40 ^{3,4}	0720-1003	0720-1003	Buna-N O-ring	2

1 Items available as Standard Head Assembly #3415-9001, Metric Taper Head Assembly #4415-9001 and Metric Parallel Head Assembly #5415-9001.

2 When replacing the head bolts in actuators manufactured prior to July 1, 2006, the hole for the head bolt will need to be drilled 0.4" (10mm) deeper to accommodate the longer screw length.

COMMON REPLACEMENT PARTS:

3 Repair Kit: Parts contained in Repair Kit RKBC315SK___

4 Seal Kit: Parts contained in Seal Kit #3415-9019

5 After configuration code add: **SK**___ (note: the letters SK indicate stroke, follow these letters with the stroke length in decimal inches.)
If the actuator has the dual carrier option add the code **DW**___ (note: follow the letters DW with the distance between the carriers in decimal inches.)

CYLINDER DISASSEMBLY INSTRUCTIONS FOR INSTALLATION OF REPAIR KITS ONLY

1. Remove Band Cylinder from machinery.
2. Remove any foot mounting hardware external shock absorbers or switches if present. Remove the four Head Bolts (12) and the two Set Screws (5) from each cylinder Head (7). Remove the Clamp Pad (4), and Clamp (3). Remove Heads.
3. Remove Screws (37) from End Caps (23) and slide End Caps off Carrier (30). Slide off Carrier Cover (24). Remove top Dust Band (2). Remove Screws (26) to release Piston Blocks (39). Slide Carrier (30) slightly either direction to remove Piston Blocks (39) and release Piston Bracket Assembly (16). Slide Piston Bracket Assembly out end of tube.

CAUTION: DO NOT remove the Carrier or the rails. Ball Bearings will fall out as a result.

4. Dislodge the inner Sealing Band (1) from its groove by gently pressing down on the band with an O-ring Pick or similar tool. (When doing so, take care that NO SCRATCHES are made in the tube bore slot.) Remove Sealing Band.

CYLINDER ASSEMBLY INSTRUCTIONS**1. CLEAN AND LUBRICATE**

Thoroughly clean all components, particularly the tube bore slot and bands. Thoroughly lubricate the tube with Magnalube®-G grease.

2. READY INNER SEALING BAND

Lubricate rubber strip on both sides of new Sealing Band (1) with Magnalube®-G grease. Slide Sealing Band (1) into cylinder Tube (19) with rubber portion facing up. Center band in Tube so equal lengths of Band extend out both ends.

CAUTION: Metal edges of Sealing Band are sharp. Exercise caution to avoid injury to yourself of the Band and Tube when inserting.

3. INSTALL PISTON ASSEMBLY

Generally U-Cups come pre-assembled onto the Piston/Bracket Assembly (16). [If they did not, install new lubricated U-Cups on the Piston-Bracket Assembly with seal lips facing out]. Install the Cushion Seals (18) [small end facing out] onto Piston-Bracket Assembly (16) and rotate to seat them in their grooves.

NOTE: If the cylinder will be used with optional shock absorber packages, do not install the Cushion Seals. Doing so will adversely affect shock performance.

Place a small amount of grease into the Cushion Seals on each end of the Piston. Fill indentations on both sides of the Piston Bracket Assembly (16) completely with grease and install into the cylinder Tube (19) feeding the Sealing Band (1) between the Piston and Bracket. If the cylinder is equipped for switches, it is important to note which side of the Piston Bracket Assembly (16) contains the Magnet, as switches must be attached to that side of the Tube. Slide the Piston Bracket Assembly (16) to the Carrier (30), slide the Carrier back over the Piston and continue to move the Piston Bracket Assembly the length of the tube to seat the sealing band in its groove. Wipe away excess grease.

NOTE: If Tube and Piston were greased properly, excess grease should be present as Piston exits end of tube.

4. TRIM SEALING BAND

With a razor blade, remove rubber from extended band until flush with the end of tube. With tin snips, trim band to length indicated.

Cylinder Size	Trim Length From Tube
1-1/2" (40 mm)	.875" (22.22mm)

CAUTION: Bands inaccurately cut too long may cause serious injury to your hand when pressing the head onto the tube.

5. INSTALL HEADS

Lubricate and install new O-Rings (15) onto Head snouts. Lubricate and

install new O-rings (15) into cross ports on Heads (7). Remove Cushion Needle Valve (9) and lubricate and install new O-Rings (8) onto Cushion Needle Valves. Insert Cushion Needle Valves (9) back into Heads (7). Insert heads into tube using a slight rocking motion. DO NOT TWIST. Twisting the head during installation may cut the O-ring resulting in excessive leakage during operation.

NOTE: When inserting heads, make sure band does not get pushed backwards into tube. Rubber on band must remain flush to the tube after head installation.

Install Head Bolts (12) into heads (7). Torque Head Bolts (12) to 100-110 in.-lbs. (11.29-12.43 Nm).

6. LUBRICATE BALLWAYS

Before installing the top Dust Band (2) lubricate the ballways with a #2 Mobil HP Grease.

7. INSTALL CARRIER STOPS

Place a Piston Block (39) on either side of the Piston Bracket Assembly (16), notch on Block to face bracket. Slide the Carrier (30) over the Piston Bracket and Piston Blocks (39) until holes in the Carrier line up with holes in Piston Blocks. Apply Loctite #242 on the Screws (26) and secure stops to the carrier. There should be no slack between stops and bracket.

8. INSTALL DUST BAND

Install the top Dust Band (2) over the Carrier (30) centering it along the length of the cylinder. Slide Carrier Cover (24) into slots on top of Carrier. Apply Loctite #242 to Screws (37) and secure End Caps (23) to ends of Carrier (30). With tin snips, cut ends of top band 1/20" in from outside edge of Head (7). Place a Clamp (3) between the Sealing Band (1) and Dust Band (2). Place Clamp Pad (4) in each Head (7). Apply Loctite #242 to Set Screws (5). Tighten to secure bands.

9. CHECK ASSEMBLY

Run the Carrier (30) back and forth along the full stroke to make certain the cylinder is properly assembled before applying air. Before mounting cylinder back in application, check the cylinder's internal cushions. (If optional shock absorber kits are being used, this step can be eliminated as Cushion Seals (18) were not installed.) Push the Carrier (30) to one end. You should feel the Cushion decelerate the Carrier before the Cushion bottoms out. If the Carrier slams into the end of the cylinder, either the Cushion Seals have not been properly installed or the Cushion Needle Valve (9) is adjusted too far out.

10. REMOUNT

Before installing back in application, check your air lines to be sure they are in good condition and free of leaks. Remount and apply air. If external shock absorbers are not being used, readjustment of the Cushions may be necessary. Start by screwing the Cushion Needle Valve (9) all the way in but do not tighten, then back it out slightly. Cycle the cylinder and back the Cushion Needle Valve out as necessary to reduce the amount of cushion. This will prevent the load from slamming into an under adjusted cushion and prevent band damage caused from pressure spikes as a result of over tightening the Cushion Needle Valve.

SINGLE-END PORTING

The BC3 Band Cylinder is uniquely designed for multiple port locations including single-end porting. The lower ports on the head assembly only function when used to cross port the cylinder for single-end porting.

To convert the BC3 cylinder to a single-end port:

1. Remove access Pipe Plug fitting from the **opposite** head assembly that air lines will be installed into. Then remove the internal port Pipe Plug (13).
2. Reinstall access Pipe Plug into the bottom of Head (7).
3. Remove pipe plug (6) from head that air lines will be installed.

NOTE: Use thread sealant when installing pipe plugs.

Band Cylinder® is a registered trademark and BC3 Series is a trademark of Tolomatic, Inc. Loctite® is a registered trademark of the Loctite Corporation, www.loctite.com Magnalube®-G is a registered trademark of the Carleton-Stuart Corporation, www.magnalube-g.com

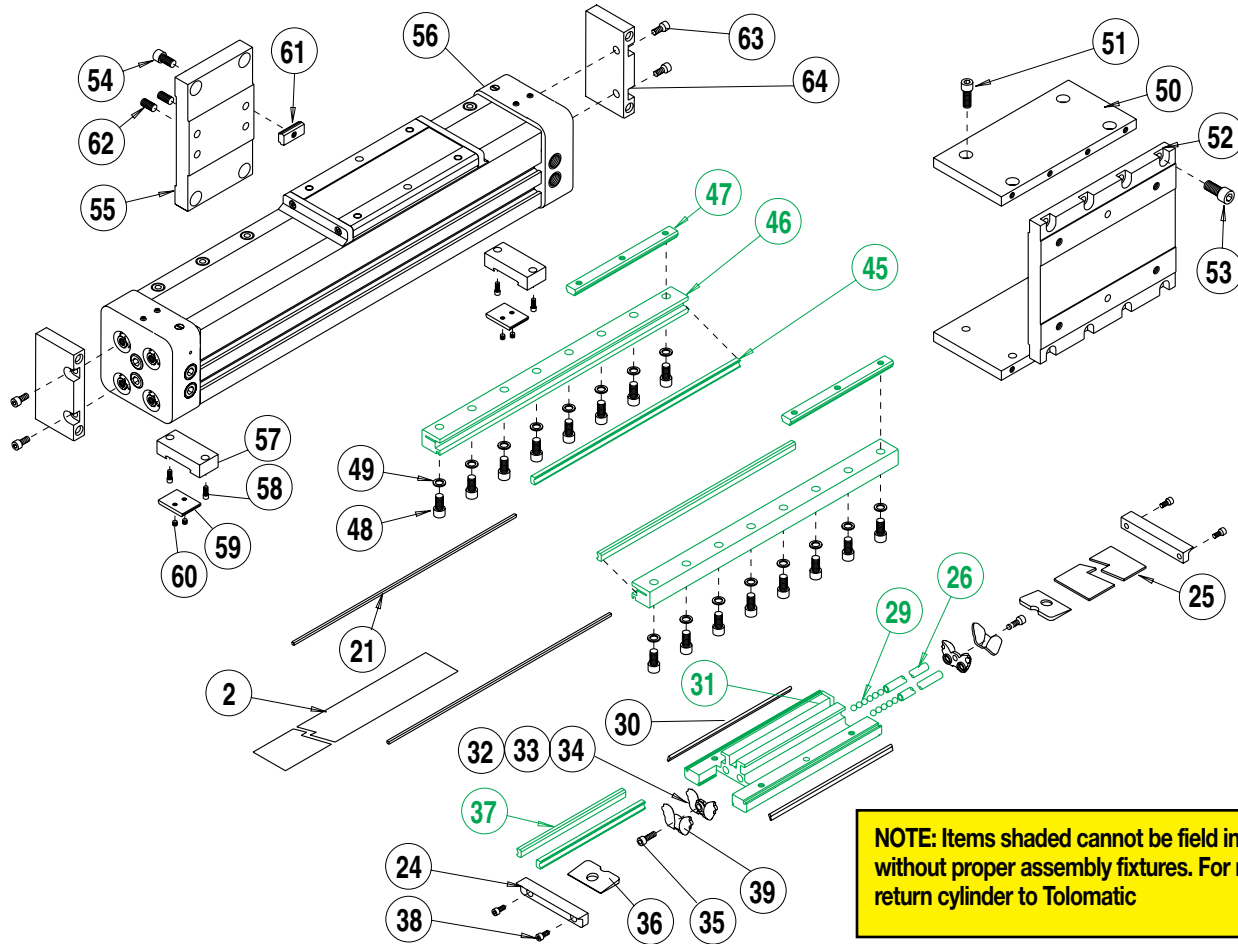

NOTE: Items shaded cannot be field installed without proper assembly fixtures. For repair, return cylinder to Tolomatic

ITEM	BC315 PART NO. or CONFIG. CODE	BC3M(M)15 PART NO. or CONFIG. CODE	DESCRIPTION	QTY.
2 ⁵	NDBBC3D15	NDBBC3MD15 NDBBC3MMD15	Replacement Dust Band (3415-1339)	1
4	3415-1045		Upper Clamp Pad	2
20	NMBBC3D15	NMBBC3MD15 NMBBC3MMD15	Replacement Magnet Band (3415-1340)	2
24	3415-2024		End Cap	2
25	3415-2022		Carrier Cover	1
26	3415-1019		Ball Return Tube	2
29	3415-1009		Ball	114
30	3415-1025		Wiper	2
31	3415-2021	4415-1235	Machined Carrier	1
32	3415-1014		Ball Return	2
33	3415-1015		Right Ball Race	2
34	3415-1032		Left Ball Race	2
35	2307-1021	4415-1024	Socket Head Cap Screw	2
36	3415-1047		Upper Band Ramp	2
37	3415-1024		Carrier Way	2
38	0910-1040	4415-1001	Socket Head Cap Screw	4
39	3415-1109		PLT Ball Return	2
45	3415-1023		Rail Way	2
46	3415-1020		Machined Rail	2
47	3415-1008	4415-1008	Rail Nut	AR
48	3415-1077	4415-1000	Socket Head Cap Screw	AR
49	3415-1059		Washer	AR
50	3415-1049	4415-1049	Plate, Conn., Dual Carrier	2
51	2317-1014	4415-1000	Socket Head Cap Screw	8

ITEM	BC315 PART NO. or CONFIG. CODE	BC3M(M)15 PART NO. or CONFIG. CODE	DESCRIPTION	QTY.
52	3415-1048	4415-1048	Plate, Dual Carrier	1
53	1209-1019	4420-1002	Socket Head Cap Screw	8
54	2317-1014	2517-1108	Socket Head Cap Screw	4
55	3415-1053		Tube Support	1
56	3415-1056	4415-1056	Head, Dual 180°	2
		5415-1056	Head, Dual 180°, Parallel Port	2
57	3415-1050		PLT, Band, Dual 180° Carrier	2
58	1024-7711	4415-1020	Socket Head Cap Screw	4
59	3415-1029	4415-1029	Clamp, Upper	2
60	3415-1455	4410-1017	Set Screw	2
61	3415-1013	4415-1013	Nut	4
62	3415-1455	4410-1017	Set Screw	2
63	1004-1064	4420-1002	SHCS (each end)	2
64	3415-1052		Foot Mount, Dual 180° Carrier	1

5 After configuration code add: **SK**__ (note: the letters SK indicate stroke, follow these letters with the stroke length in decimal inches.)
If the actuator has the dual carrier option add the code **DW**__ (note: follow the letters DW with the distance between the carriers in decimal inches.)

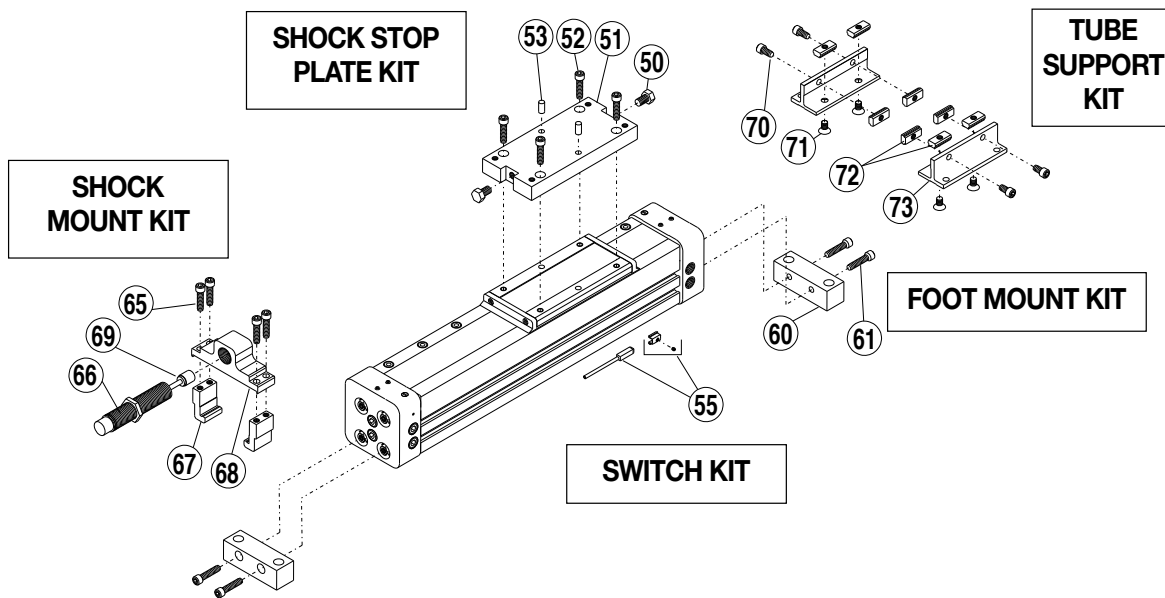

ITEM	BC315 PART NO.	BC3M(M)15 PART NO.	DESCRIPTION	QTY.
SHOCK STOP PLATE KIT ¹				
KIT ¹	3415-9004	4415-9004	Shock Stop Plate Kit	
50	3415-1057	4415-1003	Impact Bolt	2
51	3415-1039	4415-1039	Shock Plate	1
52	1004-1064	4415-1000	Socket Head Cap Screw	4
53	0610-1044	4415-1004	Dowel Pin	2
SWITCH KIT				
55	CONFIG. CODE ORDERING			
	Mounting Hardware & FE conn. included			
	CODE	DESCRIPTION		
	BT	Switch Kit, Reed, Form C, 5m		
	BM	Switch Kit, Reed, Form C, Male Conn.		
	RT	Switch Kit, Reed, Form A, 5m		
	RM	Switch Kit, Reed, Form A, Male Conn.		
	CT	Switch Kit, Triac, 5m		
	CM	Switch Kit, Triac, Male Conn.		
	KT	Switch Kit, Hall-effect, Sinking, 5m		
	KM	Switch Kit, Hall-effect, Sinking, Male Conn.		
TT	Switch Kit, Hall-effect, Sourcing, 5m			
TM	Switch Kit, Hall-effect, Sourcing, Male Conn.			
NOTE: When ordered female connector & all mounting hardware is included				

FOOT MOUNT KIT ²				
KIT ²	3415-9005	4415-9005	Foot Mount Kit (one end)	
KIT ²	3415-9025	4415-9025	Dual 180° Carrier Foot Mount Kit (one end)	
60	3415-1035		Foot Mount	2
61	6000-1481	4515-1019	Socket Head Cap Screw	4
SHOCK MOUNT KIT WITHOUT SHOCK ³				
KIT ³	3415-9003	4415-9003	Shock Mount Kit - one side (hardware only, no shock)	
65	1004-1064	4420-1002	Socket Head Cap Screw	4
67	3415-1038	4415-1038	Clamping Hook	2
68	3415-1037	4415-1037	Shock Mount	1
SHOCK MOUNT KIT WITH SHOCK ⁴				
KIT ⁴	3415-9010	4415-9010	Shock Absorber Kit - one side (Light Duty Shock)	
KIT ⁴	3415-9013	4415-9013	Shock Absorber Kit - one side (Heavy Duty Shock)	
65	1004-1064	4420-1002	Socket Head Cap Screw	4
66	0912-1067	4912-1067	Shock, Light Duty	1
	0912-1068	4912-1068	Shock, Heavy Duty	1
67	3415-1038	4415-1038	Clamping Hook	2
68	3415-1037	4415-1037	Shock Mount	1
69	0512-1018	0572-1018	Shock Stop Spacer	1
TUBE SUPPORT KIT ⁵				
KIT ⁵	3415-9006	4415-9006	Tube Support Kit	AR
KIT ⁵	3415-9026	4415-9026	Dual 180° Carrier Tube Support Kit	AR
70	0801-1251	4415-1005	Socket Head Cap Screw	4
71	3415-1046	4415-1014	Flat Head Cap Screw	4
72	3415-1013	4415-1013	BC310 Nut	4
73	3415-1044	3415-1044	Tube Support	2



Switch Ordering NOTES:

To order field retrofit switch and hardware kits for all Tolomatic actuators: SW (Then the model and bore size, and type of switch required)

Example: SWBC315RT

(Hardware and Form A Reed switch with 5 meter lead for 1.5" bore BC3 band cylinder)



Service Parts Ordering NOTES:

1 Shock Stop Plate Kit contains shock plate, impact bolts, screws and dowel pins.

2 Foot Mount Kit contains one bracket and mounting hardware.

3 Shock Mount Kit Without Shock contains one set of mounting hardware.

4 Shock Mount Kit With Shock contains one shock absorber and mounting hardware.

5 Tube Support Kit contains one tube support and mounting hardware.

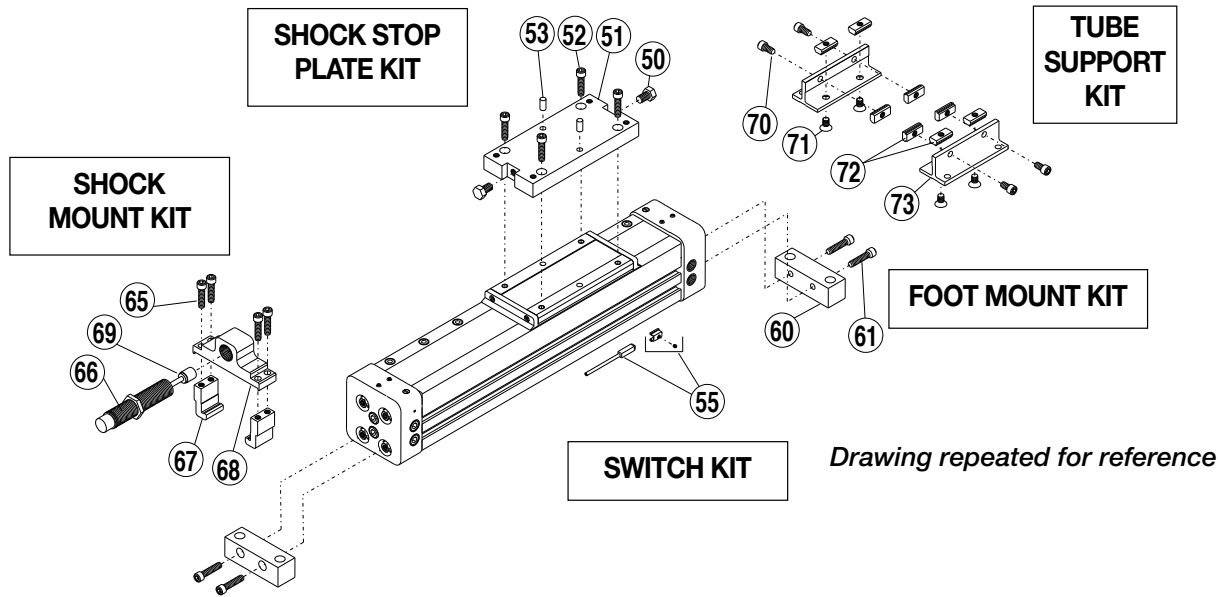

OPTIONAL ACCESSORY ASSEMBLY INSTRUCTIONS

1. SHOCK ABSORBERS

Slide a Clamping Hook (67) into each side of the Tube (20). Apply Loctite #242 to Screws (65) and secure Shock Mount Plate (68) to Clamping Hooks (67). Thread Shock (66) into Shock Mount Plate (68). Tighten Shock (66) to Shock Mount Plate (68) with Jam Nut. Apply Loctite #242 to Screws (52) and secure Shock Plate (51) to Carrier (31). Insert two Dowel Pins (53) into Shock Plate (51). Apply Loctite #242 to Impact Bolts (50) and thread into holes in ends of Shock Plate (51). Torque Impact Bolts (50) to 100-110 in.-lbs.

2. FOOT MOUNTS

Apply Loctite #242 to Screws (61) and secure Foot Mount (60) to each Head (7).

3. TUBE SUPPORTS

Four T-Nuts (72) are required on each side of the Tube (20), two T-Nuts

on bottom of Tube and two in lower slots on tube sides. Tube Supports should be secured at the required distances determined for the application to prevent Tube deflection. Apply Loctite #242 to Screws (71) and secure Tube Supports (73) to tube aligning holes in T-Nuts with holes in Tube Supports.

4. SWITCHES

On assembled cylinder, Secure Switch to open port side of cylinder with a Hardware kit (clamp and screw).

NOTE: Form A Reed Switches should not be used in TTL logic circuits. A voltage drop caused by the L.E.D. indicator will result. For applications where TTL circuits are used, please contact the factory.

WARNING: An ohmmeter is recommended for testing Reed Switches. NEVER use an incandescent light bulb as a high current rush may damage the switch.

Reed and TRIAC switches are only recommended for signalling position, not directly powering solenoids. For shifting a solenoid, a relay or resistor is recommended between it and the Reed Switch. Switch ratings must not be exceeded at any time.

NOTE: For Hall Effect Switch Magnet, be sure the S pole of the magnet (indicated with black dot) is facing toward the switch (down).

For complete Switch Performance Data, refer to the Tolomatic Fluid Power Catalog #9900-4000.

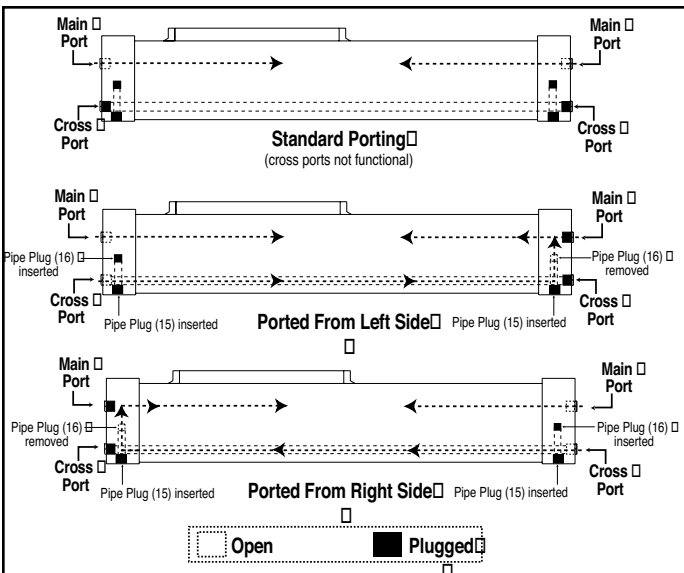

WIRING DIAGRAMS

R T & R M DC REED, FORM A

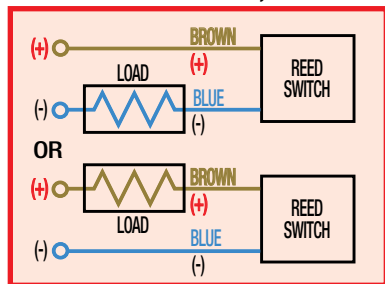

C T & C M AC REED, TRIAC

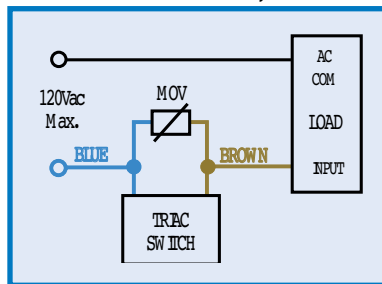

B T & B M DC REED, FORM C

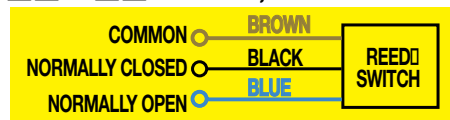

T T & T M HALL-EFFECT, SOURCING, PNP

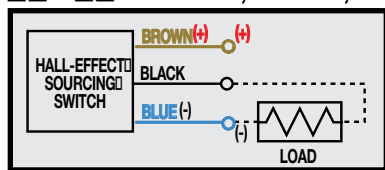

K T & K M HALL-EFFECT, SINKING, NPN

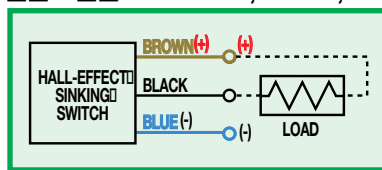

INSTALLATION INFORMATION



⚠ THE NOTCHED FACE OF THE SWITCH INDICATES THE SENSING SURFACE AND MUST FACE TOWARD THE MAGNET.



⚠ THE NOTCHED GROOVE IN THE ACTUATOR INDICATES THE GROOVE TO INSTALL THE SWITCH. CONTACT TOLOMATIC IF SWITCHES ARE REQUIRED ON ANOTHER SIDE OF ACTUATOR.

📄 Some actuators may require switch mounting on a specific side of the assembly. Call Tolomatic for details.

⚠ REPLACEMENT OF QD SWITCHES MANUFACTURED BEFORE JULY 1, 1997: It will be necessary to replace or rewire the female end coupler.



LUBRICATION AND MAINTENANCE

All Tolomatic BC3 Band Cylinders are prelubricated at the factory. To ensure maximum cylinder life, the following guidelines should be followed.

1. Filtration

We recommend the use of dry, filtered air in our products. "Filtered air" means a level of 10 Micron or less. "Dry" means air should be free of appreciable amounts of moisture. Regular maintenance of installed filters will generally keep excess moisture in check.

2. External Lubricators (optional)

The factory prelubrication of Tolomatic Band Cylinders will provide optimal performance without the use of external lubrication. However, external lubricators can further extend service life of pneumatic actuators **if** the supply is kept constant.

Oil lubricators, (mist or drop) should supply a minimum of 1 drop per 20 standard cubic feet per minute to the cylinder. As a rule of thumb, double that rate if water in the system is suspected. Demanding conditions may require more lubricant.

If lubricators are used, we recommend a non-detergent, 20cP @ 140°F 10-weight lubricant. Optimum conditions for standard cylinder operation is +32° to +150°F (+0° to 65.5°C).

NOTE: Use of external lubricators may wash away the factory installed

lubrication. External lubricants must be maintained in a constant supply or the results will be a dry actuator prone to premature wear.

3. Sanitary environments

Oil mist lubricators must dispense "Food Grade" lubricants to the air supply. Use fluids with ORAL LD50 toxicity ratings of 35 or higher such as Multitherm® PG-1 or equivalent. Demanding conditions can require a review of the application.

4. Bearing lubrication

The bearing system is prelubricated at the factory with a high quality No. 2 lithium-soap base grease. Relubrication is recommended every .5-1 million cycles using a lithium-soap base grease for optimal bearing performance. To relubricate, remove Set Screws (5), and Clamp Pad (4). Lift back dust band (2) and apply grease directly to the stationary ball ways.

5. Cushion Adjustment

Adjust the cushion needles in the cylinder heads carefully to obtain a smooth, hesitation free deceleration for your particular application. If there are questions on proper adjustment, please consult Tolomatic



3800 County Road 116, Hamel, MN 55340 USA
 http://www.Tolomatic.com • Email: Help@Tolomatic.com
 Phone: (763) 478-8000 • Fax: (763) 478-8080 • Toll Free: 1-800-328-2174

COMPANY WITH
 QUALITY SYSTEM
 CERTIFIED BY DNV
 = ISO 9001 =

All brand and product names are trademarks or registered trademarks of their respective owners. Information in this document is believed accurate at time of printing. However, Tolomatic assumes no responsibility for its use or for any errors that may appear in this document. Tolomatic reserves the right to change the design or operation of the equipment described herein and any associated motion products without notice. Information in this document is subject to change without notice.