

PB220, PB232, and PB252

1-1/4", 2" and 3-1/4" Bore

(12-26-2019) PB252 IS A DISCONTINUED PRODUCT SIZE. PARTS SHEET IS FOR REPAIR INSTRUCTIONS ONLY.

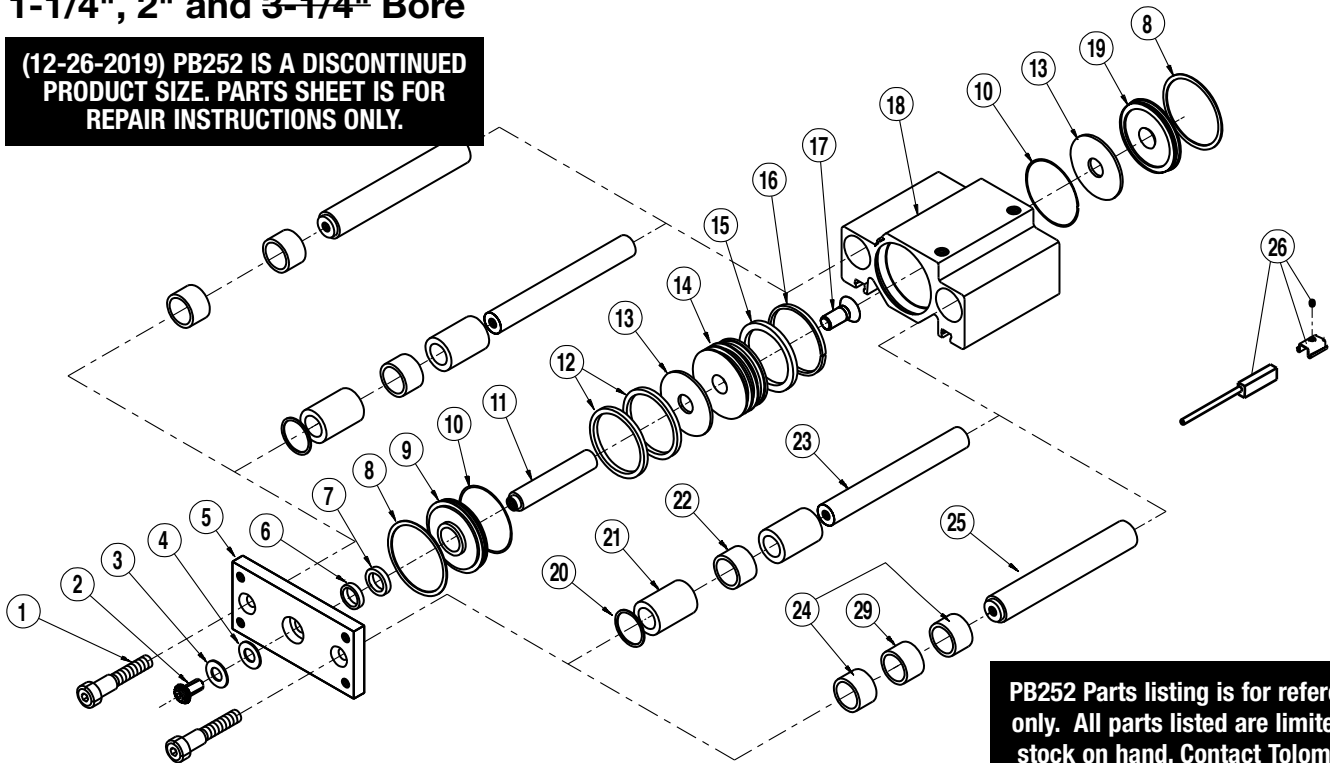

PB252 Parts listing is for reference only. All parts listed are limited to stock on hand. Contact Tolomatic regarding availability.

List of Parts

ITEMS	PART NO. or CONFIG. CODE	DESCRIPTION	PB220	PB232	PB252 (Disc.)
1.	6930-1023	FHSCS	2		
	2532-1105	FHSCS		2	
2.	2517-1126	Button Socket Head Screw	1		
	0925-1032	Button Socket Head Screw		1	
3.	2520-1079	Belleville Spring	1		
	2532-1079	Belleville Spring		1	
4.	2406-1009	Washer	1		
	N/A	Washer		N/A	
5.	2520-1068	Tooling Plate	1		
	2532-1068	Tooling Plate		1	
6.	N/A	Bearing, Pl.		N/A	
	2532-1109	Bearing, Pl.		1	
7.	2520-1080	Q-Ring, Buna-n	1		
	2532-1080	Q-Ring, Buna-n		1	
8.	2520-1029	Retaining Ring	2		
	2532-1104	Retaining Ring		2	
9.	2520-1058	Head	1		
	2532-1058	Head		1	
10.	2520-1000	O-Ring, Buna-N	2		
	1817-1012	O-Ring, Buna-N		2	
11.	2520-1051	Piston Shaft, 1" Stroke	1		
	2520-1052	Piston Shaft, 2" Stroke	1		
	2520-1053	Piston Shaft, 3" Stroke	1		
	2520-1054	Piston Shaft, 4" Stroke	1		
	2520-1055	Piston Shaft, 5" Stroke	1		
	2520-1056	Piston Shaft, 6" Stroke	1		
	2532-1051	Piston Shaft, 1" Stroke		1	
	2532-1052	Piston Shaft, 2" Stroke		1	

ITEMS	PART NO. or CONFIG. CODE	DESCRIPTION	PB220	PB232	PB252 (Disc.)
11.	2532-1053	Piston Shaft, 3" Stroke		1	
	2532-1054	Piston Shaft, 4" Stroke		1	
	2532-1055	Piston Shaft, 5" Stroke		1	
12.	2532-1056	Piston Shaft, 6" Stroke		1	
	1820-1111	U-Cup, Buna-N	2		
13.	2532-1108	U-Cup, Buna-N		2	
	2520-1102	Bumper	2		
14.	2532-1102	Bumper		2	
	2520-1059	Piston	1		
15.	2532-1059	Piston		1	
	2520-1069	Magnet	2		
16.	2532-1069	Magnet		1	
	N/A	Ring, Piston	N/A		
17.	2532-1103	Ring, Piston		1	
	0803-1243	Socket Flat Head Screw	1		
18.	2532-1105	Socket Flat Head Screw		1	
	2520-1071	Base 1" Stroke PB220	1		
	2520-1072	Base 2" Stroke PB220	1		
	2520-1073	Base 3" Stroke PB220	1		
	2520-1074	Base 4" Stroke PB220	1		
	2520-1075	Base 5" Stroke PB220	1		
	2520-1076	Base 6" Stroke PB220	1		
	2532-1071	Base 1" Stroke PB232		1	
	2532-1072	Base 2" Stroke PB232		1	
	2532-1073	Base 3" Stroke PB232		1	
2532-1074	Base 4" Stroke PB232		1		
2532-1075	Base 5" Stroke PB232		1		
2532-1076	Base 6" Stroke PB232		1		

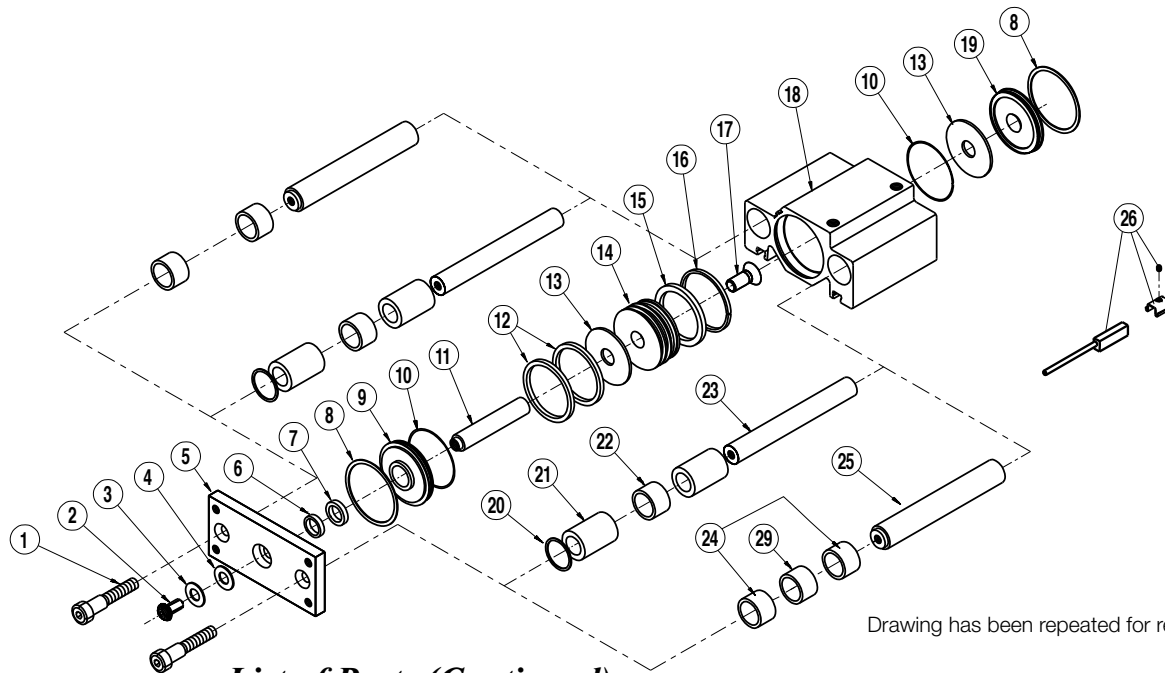

Drawing has been repeated for reference

List of Parts (Continued)

ITEMS	PART NO. or CONFIG. CODE	DESCRIPTION	PB220	PB232	PB252 (Disc.)	
19.	2520-1057	Cap	1			
	2532-1057	Cap		1		
20.	2517-1029	Retaining Ring	2			
	3010-1004	Retaining Ring		2		
21.	1004-1332	Linear Bearing 1" Stroke	2			
	1004-1332	Linear Bearing 2-6" Stroke	4			
	2532-1087	Linear Bearing 1" Stroke		2		
	2324-1011	Linear Bearing 2-6" Stroke		4		
22.	1004-1332	Spacer, 1" Stroke	2			
	2532-1087	Spacer, 1" Stroke		2		
23.	2520-1091	Linear Shaft 1" Stroke	2			
	2520-1092	Linear Shaft 2" Stroke	2			
	2520-1093	Linear Shaft 3" Stroke	2			
	2520-1094	Linear Shaft 4" Stroke	2			
	2520-1095	Linear Shaft 5" Stroke	2			
	2520-1096	Linear Shaft 6" Stroke	2			
	2532-1091	Linear Shaft 1" Stroke		2		
	2532-1092	Linear Shaft 2" Stroke		2		
	2532-1093	Linear Shaft 3" Stroke		2		
	2532-1094	Linear Shaft 4" Stroke		2		
24.	2552-1110	Composite Bearing	4			
	2532-1101	Composite Bearing		4		
	25.	2520-1081	Slide Shaft 1" Stroke	2		
		2520-1082	Slide Shaft 2" Stroke	2		
		2520-1083	Slide Shaft 3" Stroke	2		
		2520-1084	Slide Shaft 4" Stroke	2		
2520-1085		Slide Shaft 5" Stroke	2			
2520-1086		Slide Shaft 6" Stroke	2			
25.	2532-1081	Slide Shaft 1" Stroke		2		
	2532-1082	Slide Shaft 2" Stroke		2		
	2532-1083	Slide Shaft 3" Stroke		2		
	2532-1084	Slide Shaft 4" Stroke		2		
	2532-1085	Slide Shaft 5" Stroke		2		
	2532-1086	Slide Shaft 6" Stroke		2		

ITEMS	PART NO. or CONFIG. CODE	DESCRIPTION	PB220	PB232	PB252 (Disc.)
SWITCHES					
26.	RT	Switch, Reed, Form A, 5M	AR	AR	
	RM	Switch, Reed, Form A, Male Connector	AR	AR	
	BT	Switch, Reed, Form C, 5M	AR	AR	
	BM	Switch, Reed, Form C, Male Connector	AR	AR	
	CT	Switch, TRIAC, 5M Wire	AR	AR	
	CM	Switch, TRIAC, Male Conn.	AR	AR	
	TT	Switch, Source, Hall-effect, 5M Wire	AR	AR	
	TM	Switch, Source, Hall-effect, Male Connector	AR	AR	
	KT	Switch, Sinking, Hall-effect, 5M Wire	AR	AR	
	KM	Switch, Sinking, Hall-effect, Male Connector	AR	AR	
29.	2552-1118	Spacer	-	-	
1.	2552-1116	FHSCS			2
2.	2552-1114	Button Socket Head Screw			1
3.	2552-1079	Belleville Spring			2
4.	N/A	Washer			N/A
5.	2552-1068	Tooling Plate			1
6.	2552-1109	Bearing, Pl.			1
7.	2552-1080	Q-Ring, Buna-n			1
8.	2552-1104	Retaining Ring			2
9.	2552-1058	Head			1
10.	1024-1037	O-Ring, Buna-N			2
	2552-1051	Piston Shaft, 1" Stroke			1
	2552-1052	Piston Shaft, 2" Stroke			1
	2552-1053	Piston Shaft, 3" Stroke			1
	2552-1054	Piston Shaft, 4" Stroke			1
	2552-1055	Piston Shaft, 5" Stroke			1
11.	2552-1056	Piston Shaft, 6" Stroke			1
	12.	2552-1108	U-Cup, Buna-N		
13.	2552-1102	Bumper			2
14.	2552-1059	Piston			1

List of Parts (Continued)

ITEMS	PART NO. or CONFIG. CODE	DESCRIPTION	PB220	PB232	PB252 (Disc.)
15.	2552-1069	Magnet			1
16.	2552-1103	Ring, Piston			1
17.	2552-1107	Socket Flat Head Screw			1
18.	2552-1071	Base 1" Stroke PB252			1
	2552-1072	Base 2" Stroke PB252			1
	2552-1073	Base 3" Stroke PB252			1
	2552-1074	Base 4" Stroke PB252			1
	2552-1075	Base 5" Stroke PB252			1
	2552-1076	Base 6" Stroke PB252			1
19.	2552-1057	Cap			1
20.	2552-1105	Retaining Ring			2
21.	2552-1115	Linear Bearing 1-2" Stroke			2
	2332-1011	Linear Bearing 3-6" Stroke			4
22.	2552-1115	Spacer, 1-2" Stroke			2
23.	2552-1091	Linear Shaft 1" Stroke			2
	2552-1092	Linear Shaft 2" Stroke			2
	2552-1093	Linear Shaft 3" Stroke			2
	2552-1094	Linear Shaft 4" Stroke			2

ITEMS	PART NO. or CONFIG. CODE	DESCRIPTION	PB220	PB232	PB252 (Disc.)
23.	2552-1095	Linear Shaft 5" Stroke			2
	2552-1096	Linear Shaft 6" Stroke			2
24.	2552-1101	Composite Bearing			4
25.	2552-1081	Slide Shaft 1" Stroke			2
	2552-1082	Slide Shaft 2" Stroke			2
	2552-1083	Slide Shaft 3" Stroke			2
	2552-1084	Slide Shaft 4" Stroke			2
	2552-1085	Slide Shaft 5" Stroke			2
	2552-1086	Slide Shaft 6" Stroke			2
SWITCHES					
26.	RT	Switch, Reed, Form A, 5M			AR
	RM	Switch, Reed, Form A, Male Connector			AR
	BT	Switch, Reed, Form C, 5M			AR
	BM	Switch, Reed, Form C, Male Connector			AR
	CT	Switch, TRIAC, 5M Wire			AR
	CM	Switch, TRIAC, Male Conn.			AR
	TT	Switch, Source, Hall-effect, 5M Wire			AR
	TM	Switch, Source, Hall-effect, Male Conn.			AR
	KT	Switch, Sinking, Hall-effect, 5M Wire			AR
	KM	Switch, Sinking, Hall-effect, Male Conn.			AR
29.	2552-1118	Spacer			2

Disassembly - Assembly Instructions**POWER-BLOCK2 DISASSEMBLY PROCEDURE**

- To remove the Tooling Plate (#5) and Shafts (#23 or #25) first remove the Button Head Screw (#2). Note, for later reassembly, that the cupped surface of the Belleville Spring (#3) faces toward the Tooling Plate. Pull on the Tooling Plate (#5). The Tooling Plate and Shafts (#23 or #25) will slide out of the assembly.
- Push Head (#9) into bore to expose a gap between Head and Retaining Ring (#8). To remove the Head use a screwdriver to remove the Retaining Ring. The Head is now free to be removed.
- Remove the Piston/Piston Shaft Assembly from the Base (#18). Loosen Socket Flat Head Screw (#17) to remove the Piston Shaft (#11) from the Piston (#14). When removing the two U-Cups (#12) from the Piston note that the flare of the U-Cups face away from each other. In looking at the piston from the side view the two U-Cups form a "V" shape. Remove the Bumper (#13) and the Piston Ring (#16) (Note: Piston ring is not included on the PB220 size.)
- Push Cap (#19) into bore to expose a gap between Cap and Retaining Ring (#8). Using a screwdriver remove the Retaining Ring from the Cap side of the Base (#18). Remove the Cap from the Base.
- To remove the Linear Bearings (#21) or the Composite Bearings (#24) use a screwdriver to remove the two Retaining Rings from the shaft bores of the Base (#18). The Bearings (#21 or #24) may now be pushed out, along with Spacer (#22) if applicable, with a screwdriver. Note that the composite bearing models do not use a retaining ring. To remove these bearings, use a press to push them out.

POWER-BLOCK2 ASSEMBLY PROCEDURE

Clean work bench and area, check that all parts are there and without any visual damage or defects.

1. Base Assembly

(Composite Bearings) Press new Composite Bearing (#24), outside chamfered side down, into each of the two bearing bores in the Base (#18). Press an additional Bearing (#24) outside chamfered side down, into the same two bearing holes in the Base with an arbor

press until the bearing is flush with the front surface of the base. (Linear Bearings) Place new Linear Bearing (#21) into each of the bearing bore holes in the Base (#18). Depending on stroke length you may need to replace Spacer (#22) into each of the bearing bore holes in the Base. Place second Linear Bearing into each of the bearing bore holes. Install the Retaining Rings (#20) into the grooves in the bores to hold the Bearings in place.

2. Cap Assembly

- Thoroughly lubricate the center bore of the base.
- Apply Loctite #495 to the recess in the Cap (#19) then press in the Bumper (#13) with the grooves in the Bumper facing away from the Cap.
- Install an O-Ring (#10) into the cap. Place a thin coat of Magnalube®-G over the O-Ring. Push the Cap (#19); Bumper side in, into the counterbore on the back side of the Base (#18). (Note: the mounting holes on the base are closest to the front side.)
- Install a Retaining Ring (#8) in the groove behind the Cap (#19).

3. Piston Assembly

- Apply Loctite #271 to the Socket Flat Head Screw (#17) and attach the Piston (#14) to the flat end of the Piston Shaft (#11).
- Install the Piston Ring (#16) into the end groove on the Piston (#14).
- Install the two U-Cups (#12) into the two remaining grooves in the Piston (#14) note that the flare of the U-Cups must face away from each other. In looking at the piston from the side view the two U-Cups form a "V" shape.
- Place a Bumper (#13) over the Piston Shaft (#11) so that the flat side is against the Piston (#14)
- Place a thin coat of Magnalube®-G on the Piston Shaft (#11) and the U-Cups (#12).
- Push the Piston/Piston Shaft Assembly, Piston first, into the front side of the center bore of the Base (#18).

4. Head Assembly

- a. Lubricate the Quad Ring (#7) with Magnalube®-G and insert into the center of the Head (#9).
- b. Press the Retaining Ring (#8) flush into the center of the Head (#9).
- c. Install an O-Ring (#10) onto the Head. Place a thin coat of Magnalube®-G over the O-Ring and Quad Ring (#7). Guide the Head over the Piston Shaft (#11) and push the Head (#9), flat surface in, into the counterbore on the front side of the Base (#18).
- d. Install a Retaining Ring in the groove in the counterbore in front of the Head (#9).

5. Tooling Plate and Bearing Rod Installation

- a. On units with Composite Bearings only, apply a small amount of Magnalube®-G into the bearings on the base. No additional lubricant is needed with the Linear Bearings. Insert the Guide Shafts (#23 or #25) with the drilled and tapped holes towards the Tooling Plate (#5) through the bearings. Apply Loctite #271 to the threads of the two SHCS (#1) and attach the Tooling Plate to the Guide Shafts (#23 or #25).
- b. Apply Loctite #242 to the threads of the Button Head Screw (#2). Attach the Tooling Plate (#5) to the Piston Shaft (#11) with the Button Head Screw and Belleville Spring (#3). Note that the cupped surface of the Belleville Spring (#3) faces toward the Tooling Plate. On the PB220 an additional Flat Washer (#4) goes between the Belleville Spring and the Tooling Plate (#5). Tighten all screws.
- c. Cycle the assembly back and forth by hand to seat the Bumpers, End Cap and Head.

6. Switch Option

Clamp for switch will fit in either of the two grooves on the top (porting) side of the Base (#18). Secure Switch to the Base with Clamp and Set Screw. Note the scored surface of the Switch housing should face the base of the Power-Block2.

NOTE: Form A Reed Switches should not be used in TTL logic circuits. A voltage drop caused by the L.E.D. indicator will result. For applications where TTL circuits are used, please contact the factory.

WARNING: An ohmmeter is recommended for testing Reed Switches. NEVER use an incandescent light bulb as a high current rush may damage the switch.

Reed and TRIAC switches are only recommended for signalling position, not directly powering solenoids. For shifting a solenoid, a relay or resistor is recommended between it and the Reed Switch. Switch ratings must not be exceeded at any time.

NOTE: For Hall Effect Switch Magnet, be sure the S pole of the magnet (indicated with black dot) is facing toward the switch (down).

TO ORDER RETROFIT KITS: SW (then the model number and base size, and code for type of switch needed:
EXAMPLE: SWPB220RM

All Switch Kits come with 1 switch and mounting hardware.

UNIVERSAL SWITCH WIRING DIAGRAMS AND LABEL COLOR CODING

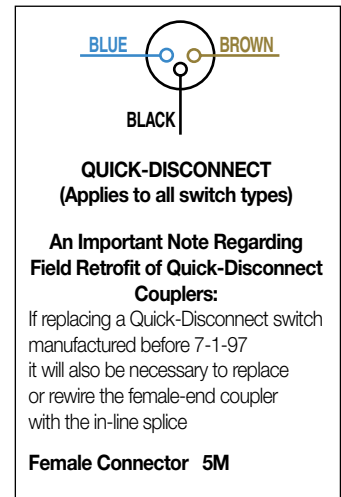
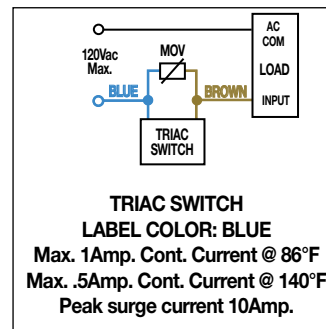
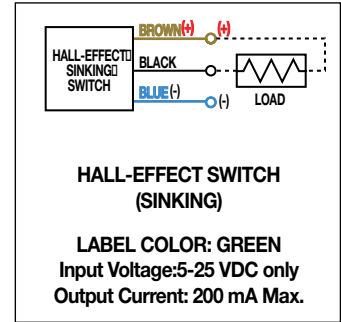
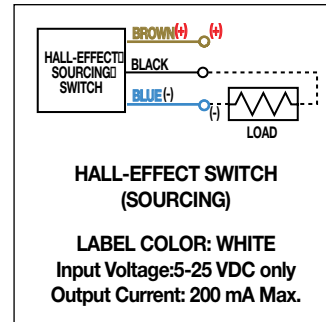
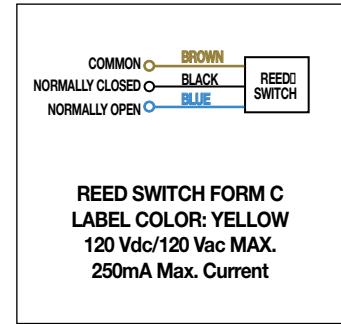
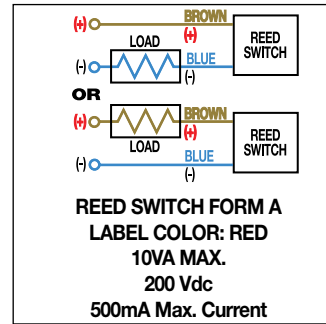

NOTE: The side of the switch with the groove indicates the sensing surface. This must face toward the magnet. For complete Switch Performance Data, refer to the Tolomatic Fluid Power Products Catalog 9900-4000

SWITCH TYPE CODE	
BT Form C Reed Switch with 5-m (meter) lead	CM TRIAC Switch with 5-m lead and QD
BM Form C Reed Switch with 5-m lead and QD	KT Hall-effect Switch (Sinking) 5-m lead
RT Form A Reed Switch with 5-m lead	KM Hall-effect Switch (Sinking) 5-m lead and QD
RM Form A Reed Switch with 5-m lead and QD	TT Hall-effect Switch (Sourcing) 5-m lead
CT TRIAC Switch with 5-m lead (Quick-Disconnect)	TM Hall-effect Switch (Sourcing) 5-m lead and QD



COMPANY WITH
 QUALITY SYSTEM
 CERTIFIED BY DNV GL
 = ISO 9001 =

3800 County Road 116, Hamel, MN 55340 USA
 http://www.Tolomatic.com • Email: Help@Tolomatic.com
 Phone: (763) 478-8000 • Fax: (763) 478-8080 • Toll Free: 1-800-328-2174

All brand and product names are trademarks or registered trademarks of their respective owners. Information in this document is believed accurate at time of printing. However, Tolomatic assumes no responsibility for its use or for any errors that may appear in this document. Tolomatic reserves the right to change the design or operation of the equipment described herein and any associated motion products without notice. Information in this document is subject to change without notice.