

### Magnetically Coupled Slide MGS100 (1-inch Bore)

For Models With: **2400-4004\_08**  
**Sintered Bronze Bearings**  
**Linear Ball Bearings**

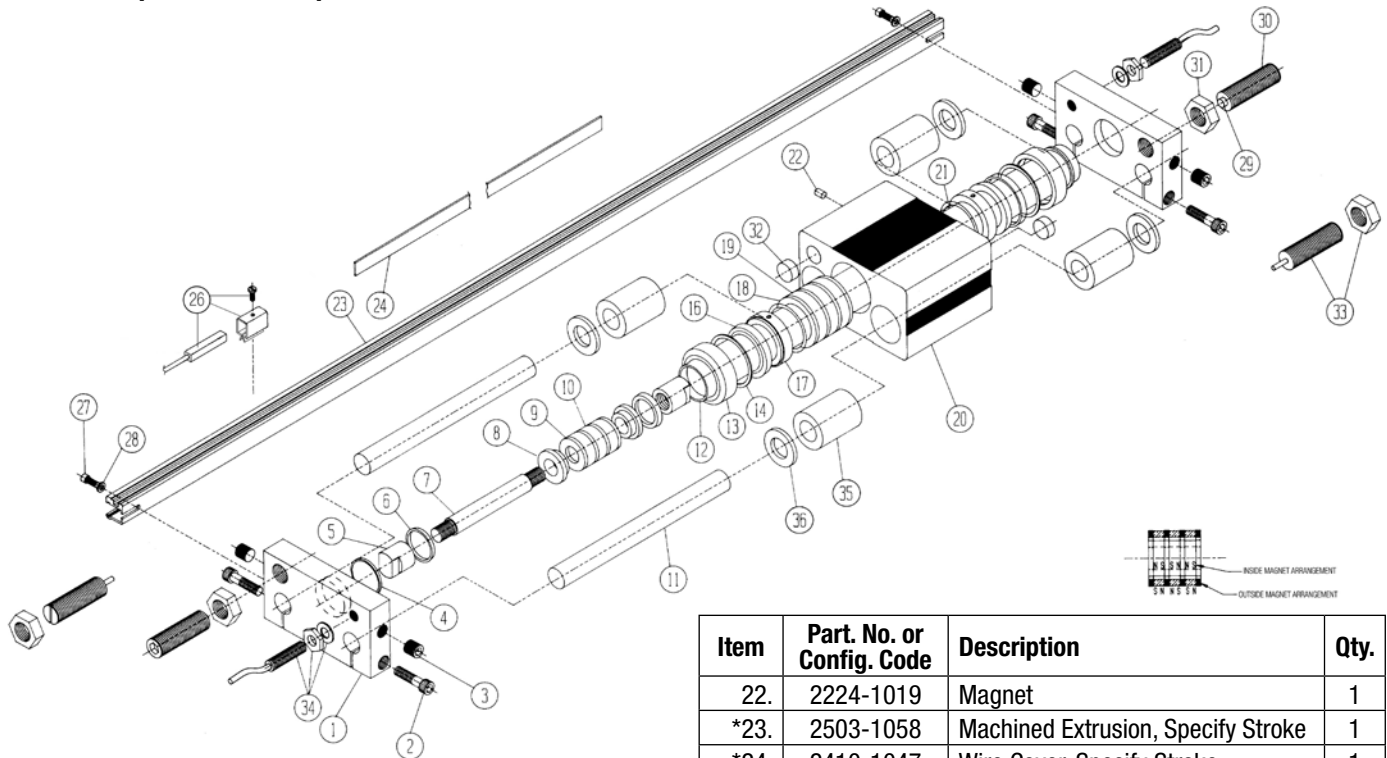

Item	Part No. or Config. Code	Description	Qty.
1.	2410-1037	End Block, 1" Bore	2
2.	1310-1015	Socket Head Cap Screw 1/4-20x1	4
3.	1014-1166	Nickel Plated Pipe Plug 1/8-27 NPT	4
†4.	2410-1054	O-Ring, Buna N, -023	2
††5.	2410-1062	Piston Spacer	2
†,††6.	2410-1070	T-Seal, 34 x 1	1
††7.	2410-1025	Piston Shaft	1
†,††8.	2410-1026	Piston Bearing	2
††9.	2410-1008	Inside Magnet	3
††10.	2410-1009	Inside Washer	4
11.	2410-1043	Slide Shaft, Specify Stroke	2
12.	2410-1041	Machined Tube, Specify Stroke	1
†, #13.	2410-1018	End Cap	2
#14.	2410-1055	Ret. Ring	2
†, #16.	2410-1016	Wiper, Dbl. Lip	2
†, #17.	2410-1010	Wear Ring	2
#18.	2410-1014	Carrier Washer	4
#19.	2410-1013	Carrier Magnet	3
#20.	2410-1038	Machined Carrier, 1" Bore	1
#21.	2410-1015	O-Ring, #2-124	2

Item	Part No. or Config. Code	Description	Qty.
22.	2224-1019	Magnet	1
*23.	2503-1058	Machined Extrusion, Specify Stroke	1
*24.	2410-1047	Wire Cover, Specify Stroke	1
26.	SWITCHES		
	RT	Switch, Reed, Form A, 5M Wire	AR
	RM	Switch, Reed, Form A, Male Conn.	AR
	BT	Switch, Reed, Form C, 5M Wire	AR
	BM	Switch, Reed, Form C, Male Conn.	AR
	CT	Switch, TRIAC, 5M Wire	AR
	CM	Switch, TRIAC, Male Connect	AR
	TT	Switch, Source, Hall, 5M Wire	AR
	TM	Switch, Source, Hall, Male Conn.	AR
	KT	Switch, Sinking, Hall, 5M Wire	AR
KM	Switch, Sinking, Hall, Male	AR	
*27.	0910-1040	Screw #6-32 x .38 SHCS	2
*28.	2410-1059	Washer	2
†29.	2406-1050	Poly Bumper Pad	2
30.	2410-1051	Machined Screw	2
31.	2410-1057	Jam Nut	2
32.	2410-1093	Bumper Stop	2
**33.	0910-1479	Light Duty Shock Absorber	2
	0910-1480	Heavy Duty Shock Absorber	2
34.	2410-1048	Proximity Switch, NPN	2
	2410-1053	Proximity Switch, PNP	2
35.	1004-1332	Linear Ball Bearing	4
	2317-1040	Sintered Bronze Bearing	4
§36.	2309-1035	Retaining Ring	4

† Included in Repair Kit 2410-9015.

†† Available only as part of complete Piston Sub-Assembly 2410-9026.

# Available only as part of complete Carrier Sub-Assembly 2410-9027.

\* Available ONLY in 2410-9019 Machined Switch Rail Kit, specify stroke.

\*\* Available as Shock Absorber Option Kit.

§ Used on models with linear ball bearings only.

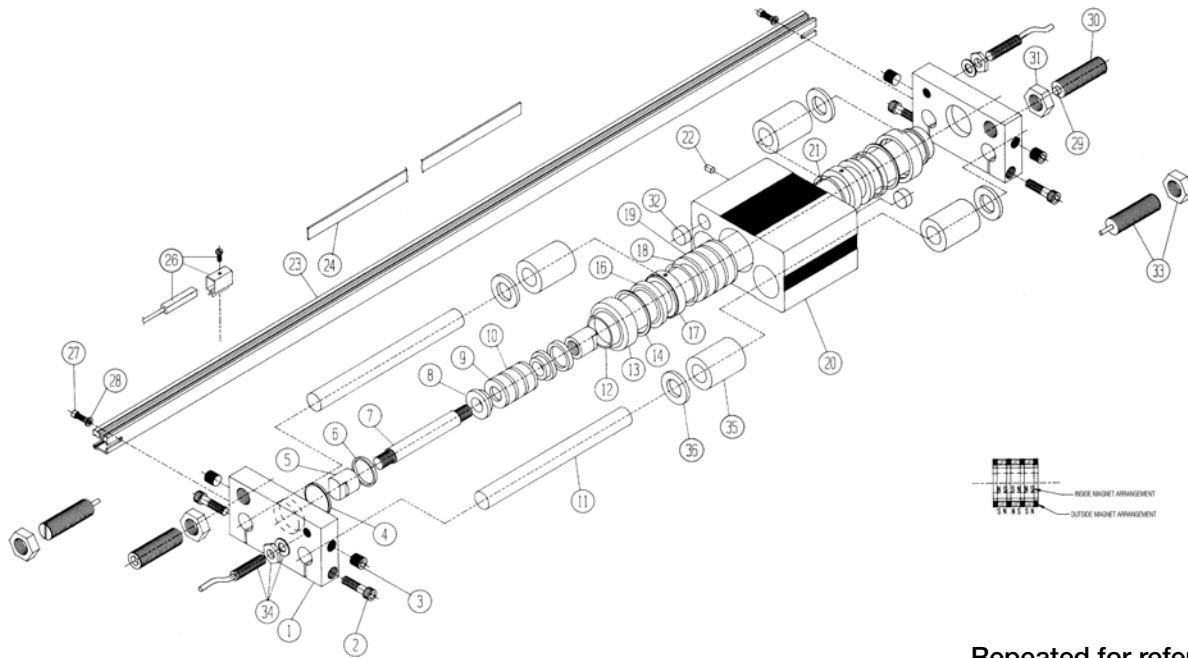

Repeated for reference

1. Remove the End Block (#1) from one end of the slide, replace the O-Ring (#4) from the center bore with a new O-Ring and set aside.
2. Uncouple the Carrier (#20) from the piston assembly and slide the carrier off of the Machined Tube (#12) and Slide Shafts (#11). Do this by inserting a rod into the machined tube and pushing the piston back while pulling the carrier off of the tube and shafts. **WARNING! THE PISTON ASSEMBLY WILL BE STUCK INSIDE OF THE CARRIER IF THE CARRIER IS NOT UNCOUPLED FROM THE PISTON ASSEMBLY PRIOR TO REMOVING THE CARRIER.**
3. Pry off the End Cap (#13) from one end of the Carrier (#19), and remove the Retaining Ring (#14), Wiper Ring (#16), and Wear Ring (#17). Place a new wear ring and wiper ring into the carrier, and reinstall the old retaining ring. Place a new end cap into the carrier and repeat the above for the opposite end.
4. Slide the piston assembly out of the Machined Tube (#12) and remove the Piston Spacer (#5) from the end of the Piston Shaft (#7) that contains the T-Seal (#6).
5. Slide the T-Seal (#6), Piston Bearing (#8), magnet assembly and the other piston bearing off of the piston shaft.
6. Place a new Piston Bearing (#8) onto the piston shaft so that the large surface of the bearing sits against the Piston Spacer (#5) at the opposite end.
7. Slide the magnet assembly back onto the piston shaft and place the other new Piston Bearing (#8) onto the piston so that the small surface of the bearing sits against the magnet assembly. Place a new T-Seal (#6) onto the piston shaft.
8. Put Loctite #242 sealant onto the threads of the piston shaft and replace the old Piston Spacer (#5) onto the shaft.
9. To ensure that the piston and the carrier with couple correctly when reassembled, place the piston assembly on one of the outside grooves of the carrier. If the magnets hold the piston centered on the carrier, mark which end of the carrier is coupled with the end of the piston that does not contain the T-seal.
10. Slide the repaired piston assembly into the Machined Tube (#12) so that the end without the T-seal goes in first. Slide the repaired carrier assembly back onto the machined tube and slide shafts, marked end first. Replace the End Block (#1).
11. Remove the End Block (#1) from the opposite end of the slide and replace its O-Ring (#4). Fasten the end block back onto the slide.
12. To couple the carrier to the piston, first remove bumpers of shocks (if applicable) so that they will not inhibit carrier movement. Next, firmly push the carrier to the opposite end of the slide to center the carrier with the piston inside. **NOTE:** If the carrier hits one of the end blocks, the carrier and piston are not coupled correctly. Remove the end block from one end and slide the carrier off of the machined tube and slide shafts. Turn the carrier around and slide back onto the unit. Replace the end block.
13. Test the repaired slide by cycling it back and forth two times at full flow.
14. For Models With Standard Bumpers: Unscrew the Machined Screw (#30) from each End Plate (#1). Remove the Poly Bumper Pad (#29) from the inside groove in each screw, and glue a new poly bumper pad in its place with Loctite Adhesive #495. Replace the machined screws back into each end plate.

Loctite® is a registered trademark of the Loctite Corporation,  
www.loctite.com

**SWITCHES**

**NOTE:** Form A Reed Switches should not be used in TTL logic circuits. A voltage drop caused by the L.E.D. indicator will result. For applications where TTL circuits are used, please contact the factory.

**WARNING:** An ohmmeter is recommended for testing Reed Switches. NEVER use an incandescent light bulb as a high current rush may damage the switch.

Reed and TRIAC switches are only recommended for signalling position, not directly powering solenoids. For shifting a solenoid, a relay or resistor is recommended between it and the Reed Switch. Switch ratings must not be exceeded at any time.

**NOTE:** For Hall Effect Switch Magnet, be sure the S pole of the magnet (indicated with black dot) is facing toward the switch (out).

**TO ORDER RETROFIT KITS:**

**SW** (then the model number and base size, and code for type of switch needed.)

**EXAMPLE: SWMGS100BT**

Where **SW** is the switch kit, **MGS** is the model, **100** is the 1" size, and **BT** is a Form C Reed Switch with 5-meter lead.

All Switch Kits come with 1 switch and mounting hardware.

**NOTE:** If adding switch to a unit that was not manufactured with switches it will be necessary to order one Magnet (22), and Machined Switch Rail Kit 2410-9019, specify stroke.

**QUICK-DISCONNECTS:**

Female Connector 5M

**SWITCH TYPE CODE**

- BT** (Form C Reed Switch with 5-meter lead)
- BM** (Form C Reed Switch with 5-meter lead and QD)
- RT** (Form A Reed Switch with 5-meter lead)
- RM** (Form A Reed Switch with 5-meter lead and QD)
- CT** (TRIAC Switch with 5-meter lead)
- CM** (TRIAC Switch with 5-meter lead and QD)
- KT** (Hall-effect Switch (Sinking) 5-meter lead)
- KM** (Hall-effect Switch (Sinking) 5-meter lead and QD)
- TT** (Hall-effect Switch (Sourcing) 5-meter lead)
- TM** (Hall-effect Switch (Sourcing) 5-meter lead and QD)

**UNIVERSAL SWITCH WIRING DIAGRAMS AND LABEL COLOR CODING**

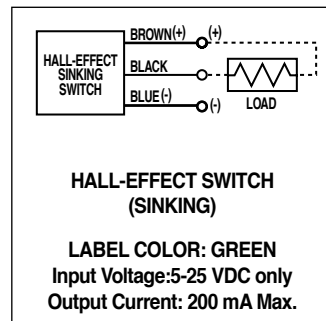
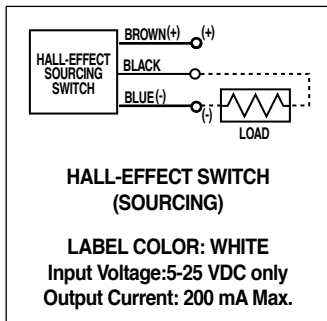
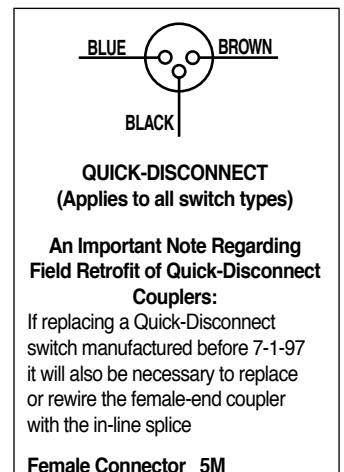
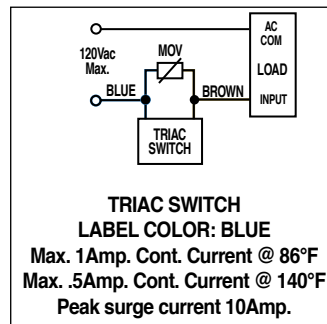
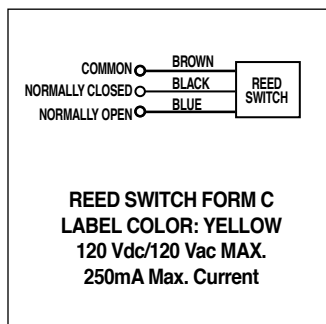
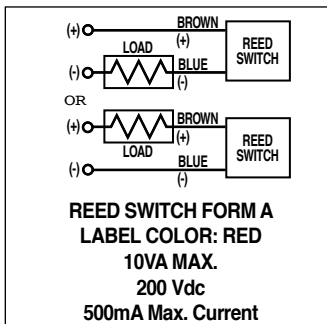

**NOTE:** The side of the switch with the groove indicates the sensing surface. This must face toward the magnet.

For complete Switch Performance Data, refer to the Tolomatic Fluid Power Products Catalog #9900-4000.



3800 County Road 116, Hamel, MN 55340  
 http://www.Tolomatic.com • Email: Help@Tolomatic.com  
 Phone: (763) 478-8000 • Fax: (763) 478-8080 • Toll Free: 1-800-328-2174



Information furnished is believed to be accurate and reliable. However, Tolomatic assumes no responsibility for its use or for any errors that may appear in this document. Tolomatic reserves the right to change the design or operation of the equipment described herein and any associated motion products without notice. Information in this document is subject to change without notice.