



**CYLINDER DISASSEMBLY INSTRUCTIONS**

1. Remove Band Cylinder from machinery.
2. Loosen Screw (19) until screw head just protrudes past end of cylinder head assembly. Tap screw with rubber-headed hammer to unseat band clamp.
3. Remove any foot mounting hardware if present then remove the four Head Bolts (18) to free Cylinder Heads (7).
4. Remove the three Screws (6, 8), Nuts (4), End Caps (1) and Bearing Rods (2). Then remove Shoulder Bolts (11) to free the Carrier Bracket (3),
5. Slide Piston Bracket Assembly (22) out end of tube.
6. Remove top Dust Band (10) by lifting one end and drawing it back across the entire length of the cylinder.
7. Remove the inner Sealing Band (9) by passing a screwdriver or similar tool through the slot in the cylinder tube to dislodge the band from the tube. (Take care in doing this step to make certain that NO SCRATCHES ARE MADE in the tube bore or slot.)

**CYLINDER ASSEMBLY INSTRUCTIONS****1. CLEAN AND LUBRICATE**

Thoroughly clean all components, particularly the tube bore slot and bands. Thoroughly lubricate the tube with a thin, uniform layer of Magnalube-G® grease. Do not use SAE-grade 30-weight non-detergent oil.

**2. READY INNER SEALING BAND**

Lubricate rubber strip on both sides of new Sealing Band (9) with grease. Insert Band into cylinder Tube (14) by passing it sideways through slot in Tube. With rubber portion facing up, center band in Tube so equal lengths of Band extend out both ends.

CAUTION: Metal edges of Sealing Band are sharp. Exercise caution to avoid injury to yourself or the Band and Tube when inserting.

**3. INSTALL PISTON BRACKET ASSEMBLY**

Generally U-Cups come pre-assembled onto the Piston/Bracket Assembly (22). [If they did not, install new lubricated U-Cups on the Piston-Bracket Assembly with seal lips facing out]. Install the Cushion Seals (23) [small end facing out] onto Piston-Bracket Assembly (22) and rotate to seat them in their grooves. Place generous amounts of grease around bore of Tube (14) on one end. Fill indentations on both sides of Piston with grease and install Piston-Bracket Assembly into Tube (14) by feeding Sealing Band (9) between Piston and Bracket. Insert Piston into the greased end of Tube and slide the length of the Tube to seat the Sealing Band in its groove. Wipe excess grease from end.

NOTE: If Tube and Piston were greased properly, excess grease should be present as Piston exits end of tube.

**4. TRIM SEALING BAND**

With a razor blade, remove rubber from extended band until flush with the end of tube. With tin snips, trim band to length indicated on table below. (Tolerance of +/- .032")

Cylinder Size	Trim Length From Tube
1" (25 mm)	.656" (16.51mm)

**5. INSTALL HEADS**

Install new lubricated O-Rings (15) onto each Head (7, 17). Insert Head into Tube using a slight rocking motion until head is flush with end of Tube. Apply Magnalube-G to threads of Head Bolts (18) and install into head. Torque Bolts to requirements shown below. (*When replacing the head*

*bolts in actuators manufactured prior to July 1, 2006, the hole for the head bolt will need to be drilled 0.4" [10mm] deeper to accommodate the longer screw length.)*  
Repeat above procedures for second head.

Cylinder Size	In.-Lbs. Torque
1" (25 mm)	100-110 (11.29 - 12.43 Nm)

**6. INSTALL UPPER DUST BAND**

With a razor blade, remove any rubber residue on the solid steel surface of cleaned Dust Band (10). Place Dust Band in slot on top of Tube (14). Remove rubber from one end of Band flush with the end of the tube. With tin snips, trim Dust Band to trim length requirements in Step 4. Insert trimmed Dust Band into Head (7) positioning band above Band Clamp (16) and tighten Screw (19). Grasp other end of Dust Band (10) and carefully pull back out of Tube slot and back over cylinder Head with affixed Band end. Lubricate Dust Band by filling grooves along both sides of rubber strip with grease. Press Dust Band back into groove in Tube.

**7. INSTALL CARRIER**

Position Carrier (3) on Piston-Bracket Assembly (22). Install Shoulder Bolts (11), Washers (5) and Nuts (4) with screw heads on port side of cylinder. Install Bearing Rods (2) in Carrier and place End Caps (1) on Tube. Install Band Insert (12) into pocket on End Cap (curved portion towards carrier). Insert Spring (13) into hole of Band Insert (12). Compress Spring and slide End Cap up to Carrier. Fasten with Screws (6 and 8). Repeat for other end. Tighten Carrier Shoulder Bolts (11) and Nuts (4).

**8. REMOVE SLACK AND AFFIX FREE END OF BAND**

Work slack from Bands by moving the Carrier from the Head with Bands secured to the opposite Head. Remove excess rubber from free end keeping it flush with end of Tube. Cut to trim length as before. Secure free end of Band by inserting Band above Band Clamp (16) and tighten Screw (19).

**9. CHECK ASSEMBLY**

Run the Carrier Bracket (3) back and forth along the full stroke to make certain that the cylinder is properly assembled before applying air.

**10. REMOUNT****OPTIONAL ACCESSORY ASSEMBLY INSTRUCTIONS****1. SHOCK ABSORBERS**

On assembled cylinder, screw Impact Bolts (29) into top of carrier End Cap with Loctite #242. Secure Shock Brackets (28) to cylinder Heads (7, 17) with Socket Head Cap Screws (27) and Loctite #242. Screw the Shock Absorber (26) into the Shock Bracket (28). Adjust the Shock Absorber nearest the carrier to bottom out the shock at its fullest stroke. Back out the shock one full turn and tighten the Jam Nut. Adjust the other Shock Absorber in the same manner.

**2. TUBE SUPPORTS**

Follow cylinder assembly instructions through steps 4. Before installing second cylinder Head (17) in step 5., slide Tube Support (40) onto cylinder Tube (14).

**3. FOOT MOUNTS**

On assembled cylinder, insert Screws (35) through holes in Foot Mount Bracket (36) and install in holes on cylinder Heads (7, 17).

**4. FLOATING MOUNT**

Completely assemble cylinder. Place Pin (31), flat side towards Carrier (3), and between the two center holes. Place Floating Mount Clamp (32) over Pin (31) and secure to the Carrier (3) with Screws (34) and Loctite® #242. Place Floating Mount Bracket (33) over Pin (31) and hold in place with a rubber band.

**BC2  
OPTIONS**

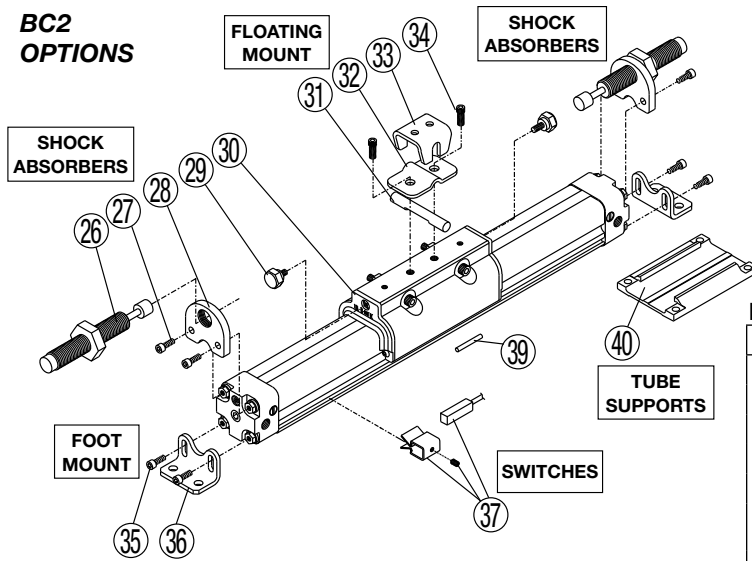

**5. SWITCHES**

On assembled cylinder, Secure Switch to open port side of cylinder with a clamp and set screw. Cycle the carrier over the Switch by hand to ensure that the carrier does not hit the switch.

**NOTE:** Form A Reed Switches should not be used in TTL logic circuits. A voltage drop caused by the L.E.D. indicator will result. For applications where TTL circuits are used, please contact the factory.

**WARNING:** An ohmmeter is recommended for testing Reed Switches. NEVER use an incandescent light bulb as a high current rush may damage the switch.

Reed and TRIAC switches are only recommended for signalling position, not directly powering solenoids. For shifting a solenoid, a relay or resistor is recommended between it and the Reed Switch. Switch ratings must not be exceeded at any time.



**Service Parts Ordering NOTES:**

- 1 Foot Mount Kit contains two foot mount brackets and mounting hardware
- 2 Shock Field Retrofit Kit contains one Shock Absorber and mounting hardware
- 3 Shock Field Mount Kit contains one set of mounting hardware only
- 4 A minimum of 2 (two) Tube Supports required per cylinder
- 5 Standard end-of-stroke shock absorbers are designed to operate without the assistance of the standard band cylinder cushion. To ensure proper shock absorber performance, make sure the air cushion is disabled.

A/R = As Required

**To Order Retrofit Kits**

All Switch Kits come with 1 switch and mounting hardware.

Retrofit ordering method: **S** **W**

**EXAMPLE:** **S** **W** **B** **C** **2** **1** **0** **R** **T**

Switch Kit      Model      Size      Switch Type Code

ITEM	PART NO.	DESCRIPTION	QTY.			
			U.S. Conv.	Metric Taper Rc Heads	Metric Parallel G Heads	
<b>SHOCK ABSORBERS<sup>5</sup></b>						
KIT	0510-9092	Shock Mount Kit <sup>3</sup>	US Standard	A/R	-	-
	4510-9092	(Hardware Only)	Metric	-	A/R	A/R
	0510-9090	Fixed Shock Absorber Kit <sup>2</sup>	Heavy Duty	US Standard	A/R	-
	4510-9090		Light Duty	Metric	-	A/R
	0510-9091	Kit <sup>2</sup>	Heavy Duty	US Standard	A/R	-
	4510-9091		Light Duty	Metric	-	A/R
	0510-9048	Adj. Shock Absorber Kit <sup>2</sup>	Heavy Duty	US Standard	A/R	-
	4510-9013		Light Duty	Metric	-	A/R
	0510-9049	Kit <sup>2</sup>	Heavy Duty	US Standard	A/R	-
4510-9014	Light Duty		Metric	-	A/R	
26	0910-1479	Light Duty Shock	US Standard	2	-	-
	4910-1337		Metric	-	2	2
	0910-1480	Heavy Duty Shock	US Standard	2	-	-
	4910-1338		Metric	-	2	2
27	0707-1010	Screw	US Standard	4	-	-
	4910-1004		Metric	-	4	4
28	0910-1332	Shock Bracket	US Standard	2	-	-
	4910-1332		Metric	-	2	2
29	0910-1335	Impact Bolt	US Standard	2	-	-
	4910-1335		Metric	-	2	2
30	0510-1015	End Cap	US Standard	2	2	2
<b>FLOATING MOUNT</b>						
KIT	0510-9007	Floating Mount Kit	US Standard	1	-	-
	4510-9007	Floating Mount Kit	Metric	-	1	1
31	0510-1009	Pin	US Standard	1	1	1
32	0910-1196	Clamp	US Standard	1	1	1
33	0910-1195	Bracket	US Standard	1	1	1
34	0910-1199	Screw	US Standard	2	-	-
	4910-1199		Metric	-	2	2
<b>FOOT MOUNT</b>						
KIT <sup>1</sup>	0510-9125	Foot Mount Kit <sup>1</sup>	US Standard	A/R	-	-
	4510-9125	Foot Mount Kit <sup>1</sup>	Metric	-	A/R	A/R
35	0915-1016	Screw	US Standard	4	-	-
	4910-1004		Metric	-	4	4
36	0910-1080	Mounting Bracket	US Standard	2	2	2
<b>SWITCHES</b>						
<b>CONFIG. CODE ORDERING</b>						
Mounting Hardware & FE conn. included						
37	<b>DESCRIPTION</b>		<b>CODE</b>			
	Switch Kit, Reed, Form C, 5m		BT			
	Switch Kit, Reed, Form C, Male Conn.		BM			
	Switch Kit, Reed, Form A, 5m		RT			
	Switch Kit, Reed, Form A, Male Conn.		RM			
	Switch Kit, Triac, 5m		CT			
	Switch Kit, Triac, Male Conn.		CM			
	Switch Kit, Hall-effect, Sinking, 5m		KT			
	Switch Kit, Hall-effect, Sinking, Male Conn.		KM			
	Switch Kit, Hall-effect, Sourcing, 5m		TT			
	Switch Kit, Hall-effect, Sourcing, Male Conn.		TM			
NOTE: When ordered female connector & all mounting hardware is included						
39	0910-1238	Switch Magnet	US Standard	1	1	1
<b>TUBE SUPPORTS<sup>4</sup></b>						
40	4510-1010	Bracket <sup>4</sup>	US Standard	1	1	1

**WIRING DIAGRAMS**

**R T & R M DC REED, FORM A**

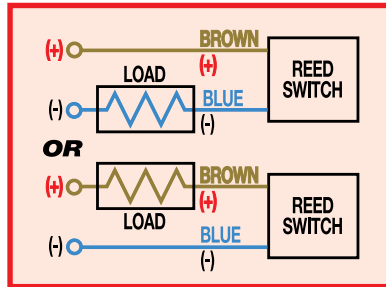

**C T & C M AC REED, TRIAC**

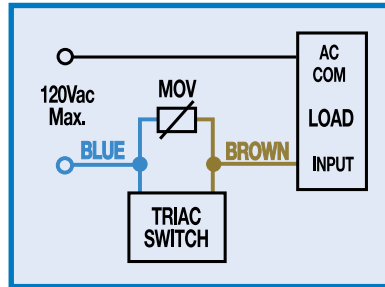

**B T & B M DC REED, FORM C**

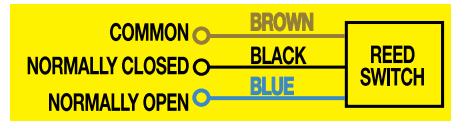

Some actuators may require switch mounting on a specific side of the assembly. Call Tolomatic for details.

**T T & T M HALL-EFFECT, SOURCING, PNP**

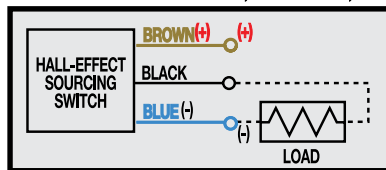

**K T & K M HALL-EFFECT, SINKING, NPN**

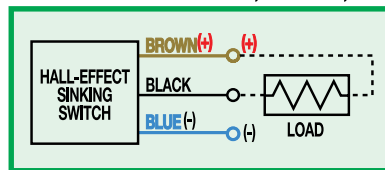

**INSTALLATION INFORMATION**



**⚠** THE NOTCHED FACE OF THE SWITCH INDICATES THE SENSING SURFACE AND MUST FACE TOWARD THE MAGNET.

**⚠** REPLACEMENT OF QD SWITCHES MANUFACTURED BEFORE JULY 1, 1997: It will be necessary to replace or rewire the female end coupler.

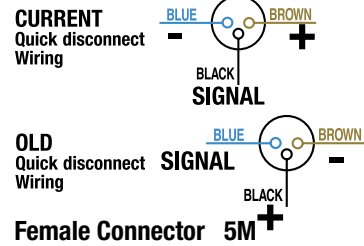

**MAINTENANCE**

The Band Cylinder® should be kept as clean as possible around the bands and Carrier Bracket.

**LUBRICATION**

All Tolomatic Band Cylinders are pre-lubricated at the factory. To ensure maximum cylinder life, the following guidelines should be followed.

- 1. Filtration-** We recommend the use of dry, filtered air in our products. 'Filtered air' means a level of 10 Micron or less. 'Dry' means air should be free of appreciable amounts of moisture. Regular maintenance of installed filters will generally keep excess moisture in check.
- 2. External Lubricators (optional)-** The factory pre-lubrication of Tolomatic Band Cylinders will provide optimal performance without the use of external lubrication. However, external lubricators can further extend service life of pneumatic actuators if the supply is kept constant.

Oil lubricators, (mist or drop) should supply a minimum of 1 drop per 20 standard cubic feet per minute to the cylinder. As a rule of thumb, double that rate if water in the system is suspected. Demanding conditions may require more lubricant.

If lubricators are used, we recommend a **non-detergent, 20cP @ 140°F 10-weight lubricant**. Optimum conditions for standard cylinder operation is +32° to +125°F (+0° to 51.6°C).

**NOTE:** Use of external lubricators will wash away the factory installed lubrication. External lubricants must be maintained in a constant supply or the results will be a dry actuator prone to failure.

- 3. Sanitary environments-** Oil mist lubricators must dispense 'Food Grade' lubricants to the air supply. Use fluids with **ORAL LD50 toxicity ratings of 35 or higher such as Multitherm® PG-1 or equivalent**. Demanding conditions can require a review of the application.

**CARRIER BRACKET ADJUSTMENT**

The tracking tension on the Carrier Bracket may be adjusted by tightening or loosening the two shoulder bolts and nuts on the bracket. To tighten or loosen the bolts on the BC210 Band Cylinder® models, use an open-end wrench and Allen wrench. Tighten the nut on the shoulder bolt until there is no lateral movement of the bolt. Then, equally tighten each nut on the shoulder bolts while moving the carrier by hand along the length of the stroke. When all lateral play in the carrier is eliminated and free movement along the length of the stroke is maintained, the carrier bracket is adjusted properly.

**CAUTION:** Make certain not to overtighten the Carrier Bracket adjustment screws. It is possible to tighten them enough to keep the Carrier and Piston from moving. Tightening the Carrier Bracket directly affects the cylinder's breakaway. The tighter the adjustment the higher the breakaway.

**CUSHION NEEDLE ADJUSTMENT**

Adjust the cushion needles in the cylinder heads carefully to obtain a smooth, hesitation free deceleration for your particular application. If there are questions on proper adjustment, please consult Tolomatic, Inc.



COMPANY WITH QUALITY SYSTEM CERTIFIED BY DNV = ISO 9001 =

3800 County Road 116, Hamel, MN 55340 USA  
 http://www.Tolomatic.com • Email: Help@Tolomatic.com  
 Phone: (763) 478-8000 • Fax: (763) 478-8080 • Toll Free: 1-800-328-2174

All brand and product names are trademarks or registered trademarks of their respective owners. Information in this document is believed accurate at time of printing. However, Tolomatic assumes no responsibility for its use or for any errors that may appear in this document. Tolomatic reserves the right to change the design or operation of the equipment described herein and any associated motion products without notice. Information in this document is subject to change without notice.